

The American Gamelan Institute (AGI), founded in 1981, is an organization devoted to publishing, recording, distributing and making available information on all aspects of Indonesian performing arts and their international counterparts. The first issue of **BALUNGAN** was printed in 1984; this is the seventeenth issue. Since Volume 9–10, 2004, the online edition has included additional media and text files. AGI also maintains an online library with fonts, scores, and writings that may be freely downloaded for educational use.

BALUNGAN is an international peer-reviewed journal presenting scholarly and artistic perspectives on Indonesian and international gamelan music and related performing arts. The goal of **BALUNGAN** is to encourage a dialog between scholars and artists involved with this complex ensemble and its many associated traditions in Indonesia and elsewhere. The intention is to provide a deeper understanding of the work of the scholar and the artist, to the benefit of both.

Subscriptions

Institutional subscriptions are \$100 per year. This includes a print copy of the current issue and an unlimited site license for the online edition. "Friends of AGI," with a \$25 per year suggested donation, receive a print copy of the current issue, and subsidize the production of free issues distributed in Indonesia.

Submissions

BALUNGAN actively seeks new material that supports the editorial mission: to speak to and to be of value to both artists and scholars. Print or multi-media materials may be submitted for both the print and on line editions of **BALUNGAN**. Scores or writings that are not published can be entered into the AGI catalog, or made available in the AGI online library. Material in Indonesian is welcome.

The website of the American Gamelan Institute is
<http://www.gamelan.org>
Email: agi@gamelan.org (office), jody.diamond@gamelan.org (editor),
jarms@gamelan.org (Jay Arms, co-editor)

All issues of *Balungan*, including video and audio files, are online at
<http://www.gamelan.org/balungan>

BALUNGAN is a publication of the American Gamelan Institute.

ISSN# 0885-7113

Publisher

American Gamelan Institute

Editor

Jody Diamond

Co-Editor

Jay Arms

Assistant Editor

Linda Hibbs

Administrative Director

Ken Hullican

Indonesian Production Coordinator

León Gilberto Medellín

Contributing Editors

Michael Asmara
Peni Candra Rini
Elizabeth Clendinning
Matthew Cohen
Bethany Collier
Ed Garcia
Irwansyah Harahap
Sean Hayward
Zach Hejny
Palmer Keen
Jessa Loranger
León Gilberto Medellín
Maria Mendonça
Wahyu Thoyyib Pambayun
Jarrad Powell
Maully Purba
Joko Purwanto
Janet Purwanto
Franki Raden
I Wayan Sudirana
Melathi Suryodarma
Steven Tanoto
Dustin Wiebe
Evan Ziporyn

Feline Keyboard Entry

Billy the Black Cat

EDITORIAL

Composers have ideas not only about music—they also think about music-making, audience interaction, community building, instrument construction. And their scores may specify vastly different realms of performance instructions. This issue's selection explores a range of concerns. Djoko Waluyo's composition *Lintang* manifests a particularly Javanese approach to vocal harmony; Sean Hayward provided thorough documentation as well as an interview in two languages with the composer. Benary offers her thoughts on how to start a gamelan group. Her composition *Mostly Slendro Passacaglia* requires a specific tuning of her own design; Jay Arms made a careful analysis of the pitches required to play it on other gamelan, and devised an interlocking duet to replace one of the parts. Following an essay describing the presence of gamelan in an educational setting, Diamond's *Anyone Can Play* is for a full gamelan, but not trained players. Sutanto, using text to represent instrument sounds, chose to invite others to suggest performance instructions for *Allahuakbar*. Aris Daryono provides information for a computer program needed to play *5 (lima)* as well as a score for the gamelan.

How do we learn a new music, or a new musical language? How do we search for and formulate concepts and constructs in a search to understand a new musical world in which we wish to take part? Roger Vetter takes us on a journey through "beginner's mind," as he uses his theoretical and analytical tools to make sense out of the music in which he found himself immersed.

While this issue was being prepared, composer and gamelan builder Barbara Benary passed away. She had edited an edition of *Ear Magazine* (Issue Vol. 8 No. 4) on Indonesian Arts in 1983—as a kind of precursor to *Balungan*. It contained a directory (which was reprinted the same year in the first issue of this journal) listing the then 100 gamelan ensembles in the U.S.; today that number has more than doubled. Benary herself composed extensively for gamelan; we are honored to present one piece here and extensive collections of her work online.

It has been 35 years since the first issue of *Balungan* appeared. Much has changed—how we communicate with each other, and how much more we are aware of ourselves as members of an international community of musicians, composers, scholars, and educators.

In recognition of the now global reach of gamelan, and to share a sense of ownership and widen our editorial resources, we are inviting people to join the *Balungan* team by becoming Contributing Editors; see page two for a list. Their names here show support for the mission of this journal: to encourage a dialogue between artists and scholars, and to share information that takes us all into a deeper understanding of the arts we practice. To all the new participants—and to those who will join us in the future—a warm welcome.

— jody diamond & Jay Arms, editors

CONTENTS

	ONLINE
2	Digital Edition & Contributing Editors
	INTERVIEW & SCORE
3	Djoko Waluyo: How Can I Explain Feeling? (English and Indonesian) <i>Sean Hayward</i>
9	Lintang <i>Djoko Waluyo, notes by Sean Hayward</i>
	ESSAY & SCORE
13	Recipe for Starting a Gamelan Group <i>Barbara Benary</i>
15	Mostly Slendro Passacaglia <i>Barbara Benary, notes by Jay Arms</i>
	INSTRUMENTS
26	How to Build a Bamboo Angklung <i>Barbara Benary</i>
	FESTIVAL
32	International Gamelan Festival Solo 2018
	ESSAY & SCORE
33	Gamelan: a cross-cultural creative context for community music making <i>Jody Diamond</i>
34	Prelude: Anyone Can Play <i>Jody Diamond</i>
	SCORE
36	Allahuakbar <i>Sutanto Mendut, with others' contributions</i>
	MONOGRAPH
49	Formal Aspects of Performance Practice in Central Javanese Gamelan Music <i>Roger Vetter</i>
	SCORE
63	5 (lima) <i>Aris Daryono</i>
	POEM
76	Pamor [As One] <i>Peni Candra Rini</i> (Javanese & Indonesian) <i>Stuart Robson</i> (English translation)
	VIDEO (inside back cover) <i>Mandala Salam: an invitation</i>

ONLINE RESOURCES

Balungan Vol. 13 Online Digital Edition

Online access: www.gamelan.org/balungan

(This material will be on the “current issue” page until the next volume is published, then it moves to “back issues.”)

Monograph

Formal Aspects of Performance Practice in Central Javanese Music, by Roger R. Vetter. M.A. Thesis, University of Hawaii at Manoa, 1977. PDF file of complete original manuscript.

Audio and Video Recordings

Mostly Slendro Passacaglia, by Barbara Benary. Audio recording from *New Gamelan/New York*, Gamelan Son of Lion Records GSOL CD-1.

Wayang Esther: A Purimspiel. Video. Music and libretto by Barbara Benary, puppets by Barbara Pollit and Joko Susilo, with Gamelan Son of Lion and guests.

Karna, a shadow puppet opera. Video. Scenes from a wayang by Barbara Benary, with Son of Lion and singers.

Lintang, by Djoko Waluyo. Video of a performance with Gamelan Kyai Doro Dasih, directed by Djoko Waluyo, from the World Music Festival at California Institute of the Arts in 2018.

Barbara Benary Score Collections

Benary was assiduous in documenting her compositions for gamelan. Volumes 1–4 group the pieces by process, style, and tuning; volumes 5 and 6 were her later works. See www.gamelan.org/composers/benary

Vol. 1: The Braid Pieces. These six works— some of Benary’s earliest compositions for gamelan— are all based on a systematic process of “braiding” pitches in particular procedures to produce elaborate formal structures and layered textures.

Vol. 2: Satires. Illustrating Benary’s sense of humor, these works juxtapose gamelan idioms with other musical genres, such as ragtime, blues, swing, and Appalachian fiddle.

Vol. 3: Pieces in a Single Tuning. Pieces in either slendro or pelog, some composed for various theatrical purposes, as well as several elaborate process compositions.

Vol. 4: Pieces in Mixed Tuning. Benary combines pelog and slendro to create complex harmonic possibilities for compositions that stylistically draw on concepts like process and randomness.

Vol. V. [Untitled], Vol. VI. [Untitled]: Scores for Benary’s last gamelan compositions, written in Finale (western notation) with ciphers under each note head. This combined “front-weighted” notation is used by many of the composers in Gamelan Son of Lion.

Compositions by Aris Daryono

Recordings of Daryono’s compositions are on Soundcloud at soundcloud.com/aris-daryono

Videos of performances and two interviews with Daryono from 2011 can be found on YouTube at youtube.com

Several scores by Aris Daryono may be downloaded at www.gamelan.org/composers/daryono

Future Balungan publications and projects

Gamelan Festivals 2018: Munich and Solo

Performance Edition: *Concerto for Piano with Javanese Gamelan*, by Lou Harrison

Instrument Building and Composition

Dustin Wiebe, editor

Gamelan Notation: the known and the new

Steven Tanoto, editor

Contributing Editors

Michael Asmara

Peni Candra Rini

Elizabeth Clendinning

Matthew Cohen

Bethany Collier

Ed Garcia

Irwansyah Harahap

Sean Hayward

Zach Hejny

Leilani Hermiasih

Palmer Keen

Jessa Loranger

León Gilberto Medellín

Maria Mendonça

Wahyu Thoyyib Pambayun

Jarrad Powell

Mauliy Purba

Joko Purwanto

Janet Purwanto

Franki Raden

I Wayan Sudirana

Melathi Suryodarma

Steven Tanoto

Dustin Wiebe

Evan Ziporyn

Contributing Editors share ideas, contribute work, review submissions, and encourage others to become part of our ongoing endeavor to support and document “all forms of gamelan and their international counterparts.” If you would like to participate, contact jody.diamond@gamelan.org or jarms@gamelan.org.

INTERVIEW

Djoko Waluyo: How Can I Explain Feeling?

by Sean Hayward

This interview was conducted in Indonesian, which follows the English translation.

Hayward: Tell me about your early life. How did you begin studying gamelan?

Waluyo: My immediate family didn't play, but they had long-standing connections with the Solo Kraton. My father traced his family tree back to Sunan Paku Buwono III. So almost all of my ancestors worked in the Solo Kraton. My house was nearby, behind [the Kraton] in the village of Wirengan, a neighborhood where some nobles had gamelan in their houses. Almost every day, there were dance rehearsals, gamelan rehearsals, wayang kulit rehearsals. Until I was old enough to go to school, I always watched them. If my parents went to the Kraton, I always joined them. Sometimes I saw rehearsals of dances like *Bedhaya* or *Wireng*. At first I didn't want to go to school, because in school no one gave you snacks, but if you played gamelan they gave you food (laughs).

In my elementary school, starting in the third grade, there were extracurricular courses; you could sing, play

Djoko Waluyo Wimboprasetyo (b. 1946) is an esteemed artist, court musician, and composer. He is a widely respected and experienced teacher of Javanese gamelan. After nearly two decades serving as professor of music at the Indonesian Arts Institute in Yogyakarta, Waluyo moved to the United States in 1992 and began directing Javanese gamelan ensembles in California, notably at the California Institute of the Arts (CalArts), the Consulate General of Indonesia in Los Angeles, the University of California, Los Angeles, and San Diego State University. Maintaining an artistic and teaching presence in Indonesia and the United States, Waluyo has performed widely, and created award-winning music for Javanese dance-dramas and wayang kulit shadow-puppet plays. Since the 1960s he has composed hundreds of pieces, including numerous works combining Western instruments with Javanese gamelan.

After studying with Pak Djoko for four years, I had the opportunity to sit with him at his home in Valencia, California to discuss his early life, his inspirations for compositions, and his views regarding current challenges for the performance of Javanese music in the United States. The interview was conducted on May 28th, 2018.
—Sean Hayward



gamelan, or dance. I joined the gamelan. The rehearsal was in the house of a Kraton musician named Pak Darmo Wiyoko. My father was a photographer in the Kraton, but when his position was terminated in 1957, he moved to Yogya to work in the office of *Jawa Tengah Departemen Kebudayaan dan Balai Bahasa* [Central Java Language and Culture Center]. I stayed in Solo with my uncle, Raden Mas Sri Handoyo Kusumo. He could dance, play gamelan, sing; he wasn't a dhalang, but he knew a lot about wayang. He often taught me bonang and other instruments. In Solo, I sometimes studied gender with Pak Ngebehi Prawiro Pangrawit, a gender specialist at the Kraton who also taught in a Kraton school called Pamarti Putri.

I was still very young when I moved to Yogya. I met Mantle Hood in 1960 or 1962; he often discussed gender with my uncle, who had a *gamelan gadhon* in his house. Every Wednesday there were classes in wayang kulit attended by

students from many departments at Gajah Mada University.

One of the musicians was Pak Gendhon Humardani, who was the coordinator and founder of an organization called *Himpunan Siswa Budaya Yogyakarta* [Community of Students of Yogyanese Culture]. This organization offered classes in dance, wayang, and Islamic songs accompanied by frame drums (*Santi Swaran*).

Wayang rehearsals were in my uncle's house in Yogya. He taught me music that accompanies wayang kulit (*ada-ada, pathetan*, etc.). I wasn't confident enough to play kendang, so I just listened. I studied gender and rebab (and bonang when I was younger) only with my uncle. No one taught me to play kendang. I studied by listening to the radio, and sometimes watching wayang orang. When I heard them, I absorbed the kendang patterns immediately. I just learned by ear. I felt it, practicing with just my mouth.

Every fasting month the schools were on holiday. At RRI Yogya [Indonesian National Radio station in Yogya] there was a program called "Holiday School," that had gamelan. That is where I met Pak Cokro [aka KPH Notoprojo]. I was playing gender and Pak Cokro was the leader of the RRI Yogya gamelan. After I had played, he said, "Your gender playing is good, where did you learn?" I answered, "From my uncle, Raden Mas Sri Handoyo Kusumo." Pak Cokro respected my uncle very much. My uncle's gender playing was good, his rebab was good, his singing was good, but the one thing he couldn't do or didn't want to do was play siter. Even if I wanted to study it, he didn't want to teach it. He felt it wasn't a Kraton instrument. He said it was an "instrument for street musicians."

Then my older brother started a gamelan group called *Ngesti Budhaya*. There was a dance teacher who taught in the style of Surakarta; I led the gamelan. Many of the players who joined were Chinese [who didn't understand Javanese], so I made a piece using the Indonesian language. We performed wayang orang, dance, and music alone. Honestly, I didn't know very much but the players assumed that I did. They would ask me, "Pak Djoko, what is the *kendangan* for *Gendhing Padang Bulan*?" Then I would have to search, ask around, and study by myself. They thought I was very clever, but honestly my hands were tied (laughs).

When ASTI [Indonesian Academy of Dance] had not yet become ISI [Indonesian Institute of the Arts], I became the assistant to Pak Mloyowidodo, teaching Solonese gamelan. This gave me a chance to watch Pak Mloyo's style of bonang playing, as though I were studying with him. I also helped Pak Cokro by playing gender at his house when he taught a course on *bawa* [solo sung poetry], before he went to America. That was my experience learning gamelan.

Hayward: Had you already begun teaching gamelan when you were studying law at Gajah Mada University (UGM). After you graduated, did you work at all in the field of law?

Waluyo: Yes, I was teaching gamelan at UGM, in Chinese schools, and in Catholic schools. When I was in

college, I was already teaching gamelan in ASTI, especially dance accompaniment. After I graduated I worked in a bureau of law assistance. I helped someone from the village east of Prambanan with a conflict between siblings about land. I only worked in law that one time.

After that, I continued teaching gamelan, sometimes with Pak Cokro. There was a group called *Karawitan Ibu-Ibu Yogyakarta* [Women's Gamelan of Yogyakarta]; we played every Mother's Day and Kartini Day. The coordinator was Pak Cokro, and I taught the group. After I met Pak Cokro, sometimes I would go RRI Yogya, to listen to the Yogya style rebab and sometimes have discussions about the differences between Yogya and Solo styles.

When ASTI became ISI Yogya, I couldn't be promoted because my degree was in law. So, I had to write a thesis about gamelan. I wanted to write about why compositions are always changed for dance. For example, in the music for *Golek Lambangsari* the whole piece has four kenong per gong, but only three are used when accompanying dance. Also, the music used for *Srimpi Lobong* has two cengkok, but we only use one to accompany the dance. That was my thesis proposal to Professor Sudarsono. But he thought it was too technical. He said, "Don't do that. Change it to something about history." Since I frequently went to the Pakualaman, I wrote about the reasons why the Pakualaman has great status in Yogyakarta, but practice performing arts in Solonese style. That is how I got my degree.

Hayward: I also want to ask about your musical treatment (*garapan*). Why is it different from the style used in Solo now?

Waluyo: My gender playing is from my uncle. If you play gender for the first part of the piece (*merong*), you must understand the composition. Don't just simply play. For example, once I was playing kendang for *Ladrang Gondo Manyura*. I was still young, and playing very full kendang variations. Pak Ngebehi, who had bad vision and often chewed betel nut, just laughed. I asked "What was my mistake?" He responded, "You didn't make a mistake, that was right." I asked again, "Why did you laugh?" He clarified: the player has to know that the piece has a connection to wayang; it accompanies Prabu Puntadewa, a refined character. The kendang part must then also be refined, and the gender playing as well. Later, in the *inggah*, you have to know if the kendang uses *golek* or *ciblon* styles of drumming, because the gender part is different. If you play *Gambirsawit*, don't play a lot, just a little bit. Later if you play *Bondhet* or *Rujak Sentul* with a lot of variations, that's no problem.

ASKI [Indonesian Academy of Traditional Music] used to be close to the Kraton. Many of the teachers had been there a long time. So, another teacher, Pak Martopangrawit, wasn't brave enough to do anything different. But after the older teachers retired, Pak Marto shared his writings on *genderan*, *rebaban*, and various other subjects. His work was good, and creative, but after

that everyone just focused on his approach to gender and rebab. Today not many young people learn to play in the way I did. Once there was a discussion in *Bentara Budaya Yogyakarta*, and Pak Marto was a guest. There was a question and answer period. I asked why his gender playing between the sections of a piece (*merong* and *inggah*) was almost the same, that is, very full. He responded “Yes, yes, that is correct. Correct, Mas Djoko—but I like the way I do it” (laughs).

Hayward: I want to ask about your experience in the United States. What is the difference between teaching American and Indonesian students?

Waluyo: First, my difficulty was not being fluent in English, of course. Second, the students just thought about *cengkok* [melodic patterns]; it was difficult for them to understand the emotion and feeling in a piece. The feeling of *pathet* [a system of tonal hierarchies, associated with wayang and music] like *nem*, *lima*, and the rest—how can I convey this to American students? If you are playing gender for *Kombang Mara*, the meaning of the title, “many beetles buzzing together,” must be expressed by the gender patterns. Honestly, this is difficult, even for Indonesian students. If they are children of dhalang or *pengrawit* [expert musicians] and they are at ISI only as a formality, they already have the feeling. I once taught singing to students who were not all Javanese. There was a student from Sumatra, who had to take the class. I sang and asked the Javanese students, “How is the feeling for you? Sad?” The Javanese students replied “Yes Pak, sad.” Then the Sumatran student responded, “I didn’t feel anything from that, Pak” (laughs). So the difficulty for me in teaching Javanese gamelan is to explain the feeling. Some non-Javanese, however, have started to show that they can understand what this means, like in the book *Rasa: Affect and Intuition in Javanese Musical Aesthetics* [by Marc Benamou].

Hayward: What do you think is the biggest challenge for the future of Javanese gamelan in the United States?

Waluyo: Some groups, like the one at UC Berkeley, can perform compositions for wayang; but not here. In my experience performing [with groups] on the East Coast, when Javanese gamelan was played alongside concerts of Western orchestral music, we played large compositions, like *Gonjangan Bedhaya*. The audience was focused, and listening very closely. But not here. Many people here have the feeling that Javanese gamelan is old-fashioned. The audience here is physically present, but they don’t understand the feeling. On the East Coast, it is possible; the audience paid \$65 a ticket and the theater was full. I have asked Pak Cokro’s students about [performances] when he was here. They said it was varied, like now; there are the small pieces that we are doing, and only sometimes we play larger pieces. I’m not sure why this is the situation.

Hayward: How did you start making new compositions?

Waluyo: When I was still in high school, I was very impressed by the creations of Pak Nartosabdho and

sometimes I wanted to imitate his compositions. During the events of 1965, the rebellion of the PKI [Indonesian Communist Party], I was playing with the women’s gamelan at RRI, which was filled in by men playing gender, rebab, gambang, etc. That was when we performed my first composition, *Bung Karno Jaya* [Victorious Sukarno]. Many soldiers entered the room, and I became afraid. When we had finished playing, one of the soldiers said to me, “Playing gamelan, eh?” “Yes sir.” “Wow...what you just played was great.” He didn’t know we had just played my composition, *Bung Karno Jaya*.

After that, I made a composition called *Ijo-Ijo* [Greens]. The words were in Javanese and honestly, I was writing sarcastically about the government of Suharto and the fact that the *bupati* [governmental head of a district] was from the military, the governor was from the military, everyone was from the military, and their uniforms were green. Get it? Later, when the communists were arrested in 1980 in the Ismail Marzuki Culture Center, I performed that piece and it was seen by Pak Gendhon Humardani. He asked me if it was my composition, because he was surprised that I was addressing the government sarcastically. Then, I was frankly stunned because Pak Narto said that it was a good composition.

After that, I made a composition for *terbang*. I rearranged it for gamelan, and I shared it at RRI. The title was *Kuswa Wirangrong*. The next morning, Pak Cokro came to my house and asked “What was the piece you played yesterday in Ngesti Budhaya, Mas Djoko?” “I composed that,” I said. He said that he liked it and we continued playing it. The composition ended up in Judith Becker’s book, *Traditional Music in Modern Java*. She thought it was Pak Cokro’s piece, but really I wrote it.

Hayward: When you write a new piece, where is your inspiration from? Are you inspired by both musical and extramusical elements?

Waluyo: When I was at ASTI, I was often asked to accompany dance drama. Sometimes I would wake up in the middle of the night at one or two o’ clock and hear the sound of a gamelan. I would think, for example, “Oh, this would be good for an angry situation.” I wrote ideas down until the whole area near my bed was covered in notecards filled with those melodies, one for anger, one for love, and more. From this, the pieces would emerge.

I am also inspired by nature. My composition *Musim Gugur* [Autumn] takes inspiration from a time when I was sitting and looking at trees that had started to lose their leaves, and were full of crows. Another time, when I was still a student, I joined a tour that traveled from Yogya by bus. I saw teak trees, just after the rain, with the rays of the sun, and dew still clinging to the leaves. From this I made a composition called *Janggleng Ireng* [Teak Tree Seed]. When I was a child, if there was a full moon I played outside in the yard, and saw many stars. That was the inspiration for my piece *Lintang* [Stars]. To make the three-part vocal harmony, I composed the first part and then I would sing and try to

find a connection between notes to make the other parts.

Hayward: What were some of the happiest moments in your life as a gamelan musician and teacher?

Waluyo: Once, at CalArts, I was very happy because there were three students who joined the gamelan: one played *mridangam* [South Indian barrel drum], one played cello, and one played piano. The pianist learned gender, the *mridangam* player studied kendang, and the cellist played rebab. In the recital, they performed *Budheng-Budheng*. That performance was very good for Americans who had only ever studied with me here.

Another time, when I young, I was asked to arrange the music for a dance drama. I hadn't done that yet. But the choreographer came to my house, and asked me to do it, so I quickly finished it. I can only do that if someone comes and forces me. That is my weakness, especially now that I am older. But if I have a new inspiration, I can still make a composition very quickly. ▀



Bagaimana Saya Menerangkan Rasa?

Interview in Indonesian

Hayward: Waktu Pak Djoko masih kecil, bagaimana cara hidup Anda? Terus bagaimana mulai belajar gamelan?

Waluyo: Keluarga saya orang-orang yang tidak mampu, tetapi semua keluarga saya sejak dulu memang ada koneksi dengan Kraton [Solo], karena bapak saya masih ada silsilah dengan Sunan Paku Buwono III. Jadi hampir semua leluhur saya bekerja di Kraton Solo. Rumah saya di belakang Kraton Solo di kampung Wirengan. Lingkungan saya sejak kecil ada rumah-rumah pangeran yang punya gamelan. Hampir setiap hari ada latihan tari, latihan gamelan, latihan wayang kulit. Saya selalu lihat itu sampai saya umur harus masuk sekolah. Kalau orang tuanya masuk Kraton, saya selalu ikut. Kadang-kadang ada latihan tari Bedhaya, tarian Wireng, saya ikut melihat. Dulu saya tidak mau sekolah, karena di sekolah tidak ada yang kasih makanan tetapi kalau

main gamelan dikasih makan (tertawa).

Di sekolah SD saya, setelah mulai kelas III, ada mata pelajaran ekstrakurikuler, bisa menyanyi, bisa main gamelan, bisa menari. Waktu itu saya ambil gamelan. Latihannya di rumah seorang musisi Kraton yang tua, namanya Pak Darmo Wiyoko. Bapak saya fotografer Kraton, nanti banyak pegawai Kraton diberhentikan termasuk bapak saya. Setelah itu bapak saya pindah ke Yogya tahun 1957. Dia bekerja di kantor Jawa Tengah Departemen Kebudayaan dan Balai Bahasa. Saya tinggal di Solo terus sama paman saya, namanya Raden Mas Sri Handoyo Kusumo. Dia bisa menari, main gamelan, nembang, dan dia tidak bisa ndhalang tetapi tahu banyak tentang wayang. Paman saya sering mengajar saya bonangan dan sebagainya. Di Solo, saya juga pernah belajar gender dengan Pak Ngabehi Prawiro Pangrawit. Dia spesialis penggender Kraton dan mengajar di sekolah Kraton namanya Pamarti Putri.

Terus saya pindah ke Yogya. Di Yogya tahun 1960 atau 1962, saya ketemu Mantle Hood. Tetapi saya masih pakai celana pendek. Dia sering ada diskusi tentang gender sama paman saya. Di rumah paman saya, ada gamelan gadhlon dan setiap hari Rabu ada semacam kelas wayang kulit. Yang main mereka mahasiswa-mahasiswa Universitas Gajah Mada dari semua fakultas. Salah satunya Pak Gendhon Humardani. Dia koordinator dan mendirikan organisasi namanya Himpunan Siswa Budaya Yogyakarta. Itu pembuka kuliah tarian, kuliah pedhalangan, terus Santi Swaran. Latihan wayang itu di rumah paman saya di Yogya. Terus saya diajarin Ada-ada, pathetan dan mengiringi wayang kulit. Saya belum berani main kendang, tetapi saya hanya dengar. Yang saya belajar sama paman saya itu rebab, gender, dua itu saja; dan bonang waktu saya masih kecil. Saya sendiri tidak ada yang diajarin kendang. Terus saya belajar dari radio, kadang-kadang melihat wayang orang. Kalau dengar, saya langsung masuk kendangan. Saya belajar sendiri dari dengar. Terus saya cuma merasakan, saya praktek sendiri dengan mulut saja.

Setiap bulan puasa semua sekolah libur, terus di RRI Yogya ada acara namanya "liburan sekolah" yang punya gamelan. Terus saya kenal sama Pak Cokro waktu itu. Saya main gender, Pak Cokro pimpinan gamelan RRI Yogya. Terus setelah selesai saya ditanya "genderan bagus, belajar dari mana?" "Dari paman saya, Raden Mas Sri Hando Kusomo." Pak Cokro menghormat sekali dengan paman saya. Paman saya ada gender bagus, rebab bagus, kalau nembang bagus, tetapi yang dia tidak bisa atau tidak mau main itu siter. Kalau saya mau belajar siter dia tidak mau diajarin. Di pikiran dia, itu bukan termasuk instrumen gamelan kraton. Dia bilang "Itu arah orang ngamen." Kemudian kakak saya Djoko Suparo mendirikan grup gamelan namanya Ngesti Budhaya. Di sana ada guru tari, latihan tari gaya Surakarta. Terus gamelan yang mimpin saya. Yang ikut main di sana banyak orang Cina. Jadi saya membuat gendhing pakai bahasa Indonesia. Terus membuat pentas wayang orang, pentas tari, dan juga klenengan. Saya ini sebetulnya tidak banyak tahu, tetapi orang-orang menganggap saya tahu.

Itu tanya, “kendangan untuk Gendhing Padang Bulan itu bagaimana mas Djoko?” Terus saya harus cari-cari, tanya-tanya, dan belajar sendiri. Dikira saya pintar sekali tetapi sebetulnya tangan saya kepepet (tertawa).

Terus waktu ASTI [Akademi Seni Tari Indonesia] Yogya belum jadi ISI [Institut Seni Indonesia], saya menjadi asisten Pak Mloyo[widodo], mengajar karawitan gaya Solo. Waktu itu saya bisa tahu, “Oh, Pak Mloyo bonangan begini,” itu seperti belajar dengan Pak Mloyo. Setelah itu waktu Pak Cokro belum kesini [ke AS], dia buka kuliah vokal bawa. Saya juga membantu main gender di rumah Pak Cokro waktu itu. Itu pengalaman saya belajar gamelan.

Hayward: Waktu Pak Djoko belajar hukum di UGM [Universitas Gajah Mada], Pak Djoko sudah mulai mengajar gamelan? Setelah anda lulus, anda sudah pernah kerja dalam hukum?

Waluyo: Iya, saya masih mengajar gamelan di UGM, di sekolah-sekolah Cina, dan sekolah-sekolah Katolik. Waktu saya kuliah, saya sudah mengajar di ASTI, mengajar gamelan gaya Solo terutama iringan tari. Setelah saya lulus, saya pernah bekerja dalam biro bantuan hukum. Saya pernah membantu orang desa dari sebelah timur Prambanan. Ada sengketa di antara saudara tentang tanah. Cuma satu kali itu saya kerja sama hukum.

Habis itu, mengajar gamelan terus. Kadang-kadang bersama Pak Cokro, karena ada grup namanya Karawitan Ibu-Ibu Yogyakarta; itu main setiap Hari Ibu terus Hari Kartini. Yang koordinator Pak Cokro, dan saya yang mengajar. Setelah saya kenal Pak Cokro, kadang ke RRI [Radio Republik Indonesia] Yogya, melihat rebaban gaya Yogya dan kadang-kadang ada diskusi tentang perbedaan di antara gaya Yogya dan gaya Solo.

Kemudian ASTI jadi ISI Yogya. Sampai saya tidak bisa naik pangkat karena ijazah saya hukum. Terus saya harus membuat semacam tesis begitu tentang gamelan. Waktu itu saya mau tulis tentang kenapa gendhing itu selalu dikalahkan oleh tarinya. Misalkan iringan Golek Lambangsari; kalau lengkap itu empat kenong, satu gong. Tetapi kalau untuk mengiringi tari itu cuma tiga kenong sudah gong. Terus Srimpi Lobong lengkap itu dua cengkok, tetapi mengiringi tari itu cuma pakai satu. Itu proposal saya ditolak sama Profesor Sudarsono. Dia pikir itu terlalu teknis. Dia bilang “Jangan itu. Ganti saja yang tentang histori [sejarah].” Saya sering ke Pakualaman. Jadi saya mengajukan kenapa Pakualaman itu domisili status wilayah di Yogyakarta tetapi kesenian [mirip] Solo. Terus saya bisa dapat Doktorandus.

Hayward: Terus saya mau tanya tentang garapan Pak Djoko, karena yang sering dipakai di Solo, itu beda sekali sekarang. Jadi bedaan itu dari apa?

Waluyo: Genderan itu dari paman saya. Kalau Anda nggenderi merong harus lihat-lihat gendhingnya. Jangan pokoknya anda main saja. Misalnya, saya main kendang untuk *Ladrang Ganda Manyura*. Terus saya masih muda, main variasi kendangan penuh semua. Pak Ngabehi, dia sakit mata dan makan sirih; dia tertawa saja. Saya tanya, “Apa salah

saya?” Dia jawab, “Nggak salah, itu betul.” Jadi saya tanya, “Terus kenapa tertawa?” Dia jelaskan, yang main harus tahu ini kembali lagi ke wayang. Gendhing ini mengiringi Prabu Puntadewa, watak yang halus. Itu kendanganya harus halus, genderan itu harus halus. Nanti kalau sudah inggah, harus lihat kalau itu golek apa ciblon, karena genderan beda. Kalau Gendhing Gambirsawit jangan banyak sedikit saja, nanti kalau Bondhet atau Rujak Sentul, genderan sudah ada banyak variasi begitu tidak apa-apa.

Kemudian, ASKI [Akademi Seni Karawitan Indonesia] dulu di dekat Kraton [Solo]. Guru-guru tua masih mengajar. Pak Marto[pangrawit] belum berani apa-apa. Terus setelah guru-guru tua pensiun, Pak Marto muncul dengan tulisan cengkok genderan, rebaban, menulis macam-macam. Bagus kreatif, tetapi setelah itu, semua fokusnya genderan dan rebaban Pak Marto. Yang sekarang anak-anak ini tidak ada banyak yang bisa main seperti saya katakan.

Pernah saya ada diskusi di Bentara Budaya Yogyakarta, kedatangan Pak Marto. Ada tanya-jawab. Saya tanya kenapa genderan Pak Marto antara merong dan inggah hampir sama saja, penuh sekali itu. Dia jawab, “Iya, iya, itu betul, betul Mas Djoko. Tetapi saya suka yang gaya saya saja” (tertawa).

Hayward: Saya mau tanya tentang pengalaman Pak Djoko di Amerika Serikat. Kalau mengajar orang Amerika sama orang Indonesia, apa perbedaannya?

Waluyo: Pertama, kesulitan saya Bahasa Inggris tentu saja. Kemudian, mereka cuma menirukan cengkok; kesulitan juga memberikan rasa. Rasa pathet nem, lima dan sebagainya bagaimana saya bisa menerangkan ini pada mahasiswa Amerika? Juga kalau nggenderi *Kombang Mara*, maksudnya nama itu “banyak lebah bersuara bersama.” Rasanya itu harus membawa ke cengkok gender. Sebetulnya untuk mahasiswa Indonesia ini juga sulit. Kalau anak dhalang atau pengrawit dan ikut ISI hanya formal saja; itu sudah punya rasanya.

Tetapi saya sudah mengajar tembang; mahasiswa yang ambil tidak semuanya Jawa. Ada yang dari Sumatra, tapi harus mengambil waktu itu. Saya nembang terus tanya pada yang [mahasiswa] Jawa, “Bagaimana rasamu, sedih apa gimana?” “Iya Pak, sedih.” Terus yang [mahasiswa] Sumatra jawab, “Tidak terasa apa-apa itu Pak” (tertawa). Jadi kesulitan saya gamelan Jawa itu selalu menggunakan rasa. Ada banyak orang asing yang menulis tentang gamelan. Saya sudah pernah membaca buku, *Rasa: Affect and Intuition in Javanese Musical Aesthetics* [oleh Marc Benamou]. Jadi orang asing sudah mulai ikut apa yang dirasakan oleh orang Jawa.

Hayward: Untuk gamelan Jawa di Amerika Serikat pada masa depan, apa yang paling sulit di pikiran Pak Djoko?

Waluyo: Seperti saya lihat, di daerah-daerah lain [di AS] ada yang bisa menerima gendhing wayang seperti di komunitas Berkeley, tetapi di sini sulit. Pengalaman saya main di East Coast, gamelan Jawa main bersamaan dengan konser musik orkestra Barat. Terus kita juga harus main gendhing besar. Waktu itu, kita main *Gonjangan Bedhaya*. Penonton di sana begitu dengar sampai fokus sekali. Di

sini tidak. Orang di sini sudah tidak suka; ada rasanya seperti Jawa itu ngantuk. Karena mereka hanya fisiknya tidak merasakan rasanya yang betul. Di East Coast bisa begitu, penonton beli tiket 65 dolar, terus teater itu penuh. Saya tanya pada murid Pak Cokro tentang [pentas] waktu Pak Cokro di sini. Lebih variasi seperti saya waktu di sini, ada gendhing kecil, yang sedang, dan kadang-kadang bisa gendhing-gendhing yang besar. Saya kurang tahu bagaimana situasinya begitu.

Hayward: Dulu, bagaimana Pak Djoko mulai membuat komposisi baru?

Waluyo: Waktu saya masih SMKI [Sekolah Menengah Karawitan Indonesia] itu saya kagum pada kreasinya Pak Nartosabdho, terus kadang-kadang ingin membuat meniruniru gendhing. Waktu Peristiwa 1965, pemberotakan PKI [Partai Komunis Indonesia], saya main di RRI gamelan dengan grup ibu-bu, dilengkapi bapak-bapak main gender, rebab, gambang, dan sebagainya. Waktu itu saya ciptakan kreasi saya yang pertama, *Bung Karno Jaya*. Banyak tentara masuk tempatnya, terus saya jadi takut. Terus setelah selesai, tentara tanya “Main gamelan ya?” “Iya Pak...” “Wah, bagus ini tadi,” tentara bilang. Dia tidak tahu saya bunyikan *Bung Karno Jaya* itu.

Terus saya setelah itu, saya buat komposisi namanya *Ijo-Ijo*, terus cakupannya Basa Jawa sebetulnya saya nyindir pemerintahan Suharto waktu karena habis itu bupati tentara, gubernur tentara, semua tentara, dan tentara berpakaian ijo [hijau]. Maksud saya itu. Nanti, waktu pegang komunis muda di Taman Ismail Marzuki tahun 1980, saya mengeluarkan itu terus dilihat Pak Gendhon Humardani juga. Terus dia tanya “Karyamu dik?” Dia kaget. Maksudnya karena saya menyindir pemerintah. Juga saya terus terang itu terpengaruh karena Pak Narto bilang “gendhing dibikin bagus.”

Habis itu saya buat gendhing dari musik terbang, ganti suara saja. Terus saya berbagi di RRI. Namanya *Kuswa Wirangrong*. Paginya, Pak Cokro ke rumah “Kemarin itu di Ngesti Budaya gendhingnya apa Mas Djoko?” “Itu buatan saya.” “Oh ya, gendhingnya apa?” Dia suka dan kita main itu terus. Itu sampai sama Pak Cokro gendhingnya ditulis di buku Judith Becker. Dia kira ini ciptaan Pak Cokro, sebetulnya yang buat saya.

Hayward: Inspirasi Pak Djoko untuk bikin komposisi baru biasanya datang dari mana? Dalam musik juga di luar musik?

Waluyo: Saya itu, waktu di ASTI itu sering diminta untuk menyusun sendratari. Saya itu sekarang masih kadang-kadang malam jam 1:00 atau jam 2:00, saya bangun saya dengar ada suara gamelan. Saya pikir ini bagus untuk suasana marah misalkan. Saya catat. Sampai dekat tempat tidur saya banyak kertas kecil-kecil isinya melodi itu. Ini marah, ini cinta, macam-macam gitu. Saya kemudian dari situ berkembang. Saya sering ada inspirasi dari alam juga. *Musim Gugur* inspirasi datang waktu saya duduk di sini melihat pohon-pohon yang mulai gundul, dan banyak burung gagak. Ada lagi waktu saya masih mahasiswa ada perlawatan pergi ke satu tempat untuk main. Dari Yogya



Bapak Djoko and Ibu Endang in 1987.

satu rombongan naik bis. Ada hutan jati, setelah hujan terus sinar matahari ada embun yang masih nempel daun-daun. Dari itu saya buat gendhing namanya *Jam Lengiren*. [Komposisi] *Lintang*, bayangan ini waktu saya masih kecil kalau padang bulan saya main di halaman; di sana ada banyak bintang. Itu inspirasinya. Untuk harmoni vokal, saya buat yang Suara I (satu) dulu. Saya barangkali saya nembang terus saya mencoba hubungkan nada-nada itu.

Hayward: Ada beberapa saat yang paling senang dalam hidup gamelan Pak Djoko?

Waluyo: Dulu saya senang sekali ada tiga student [siswa Cal Arts]. Satu yang main mridangam, satu main cello, satu main piano. Itu ambil gamelan semua. Yang piano main gender, yang mridangam main kendang, yang cello main rebab. Akhirnya resitalnya *Budheng-Budheng*. Pentas itu bagus sekali untuk orang Amerika yang belajar hanya dari saya di sini.

Juga, waktu saya masih muda, saya diminta untuk menyusun untuk sendratari. Saya belum bisa membuat gendhing; yang membuat koreografi main ke rumah saya. Saya diminta membuat komposisi khusus, terus selesai cepat sekali. Kalau tidak datang dipaksa tidak bisa saya. Itu jeleknya saya, apalagi sekarang sudah tambah tua tidak boleh begitu. Kalau saya ada inspirasi, saya masih bisa membuat komposisi cepat sekali. ▀

Thanks to Laurel Grinnell for additional information and photographs. —Eds.

SCORE

Ketawang Lintang laras pelog pathet barang

by Djoko Waluyo

Notes by Sean Hayward

CONTENTS

Performance notes

Text and Translation

Balungan

Vocal Notation

Kendhang Notation

Video of performance at Cal Arts

(online at www.gamelan.org/balungan)

Performance Instructions

Buka Saron (no kendhang)

Umpak/Sesegan, Irama I, 3 x

Lagu, Irama II, 1x, with vocals

Suwuk in Umpak/Sesegan

Text

Lintang [Stars]

Lintangé sumebar pating galebyar

Ora ana mega ora ana mendhung

Rembulané ngegla-ngegla sak dhuwuring gunung

Sasat ratu siniwaka

Lintang sewu padha seba

Katon endah wengi sepi

Nyata agung pangwasaning Gusti

Stars strewn afar, shimmering

There are no clouds, there are no clouds

The moon shines resplendent over the mountain

Like a queen holding court

A thousand stars in attendance

Elegant in the still night

Truly magnificent is the power of God

(translation by Joan Suyenaga)

Balungan

Ketawang Lintang laras pelog pathet barang

Buka Saron (muted): $\overline{\text{ㄅㄅ}}$ (5)

Umpak/Sesegan

$\begin{array}{cccc} - & + & - & \\ 2 & 3 & 2 & 5 \end{array}$ $\begin{array}{cccc} - & + & - & \hat{} \\ 2 & 3 & 5 & 6 \end{array}$ $\begin{array}{cccc} - & + & - & \smile \\ 7 & 2 & \cdot & 3 \end{array}$ $\begin{array}{cccc} - & + & - & \\ 2 & 7 & 6 & (5) \end{array}$

Lagu

$\begin{array}{cccc} - & + & - & \\ 2 & 7 & 6 & 5 \end{array}$ $\begin{array}{cccc} - & + & - & \hat{} \\ 2 & 7 & 6 & 5 \end{array}$ $\begin{array}{cccc} - & + & - & \smile \\ \cdot & 6 & 7 & 2 \end{array}$ $\begin{array}{cccc} - & + & - & \\ 6 & 5 & 3 & (2) \end{array}$

$\begin{array}{cccc} \cdot & 2 & 2 & \cdot \end{array}$ $\begin{array}{cccc} \hat{} \\ 7 & 6 & 5 & 3 \end{array}$ $\begin{array}{cccc} \smile \\ 2 & 2 & 3 & 2 \end{array}$ $\begin{array}{cccc} \smile \\ 6 & 5 & 3 & (2) \end{array}$

$\begin{array}{cccc} \cdot & 2 & 2 & 5 \end{array}$ $\begin{array}{cccc} \hat{} \\ \cdot & 7 & 5 & 6 \end{array}$ $\begin{array}{cccc} \smile \\ 3 & 2 & 3 & 5 \end{array}$ $\begin{array}{cccc} \smile \\ 6 & 7 & 6 & (5) \end{array}$

$\begin{array}{cccc} \smile \\ \cdot & 5 & 3 & 2 \end{array}$ $\begin{array}{cccc} \smile \\ 1 & 2 & 3 & (2) \end{array}$

Ketawang LINTANG laras pelog, pathet barang (Irama II)

Djoko Waluyo

2	7	6	5	2	7	6	5	·	6	7	2	5	3	2	13	2
·	·	·	·	·	·	·	·	·	·	·	·	·	·	·	·	·
Lin-tang-	e	su-	me-	bar	pa-	ting	ga-	le-	byar	O-	ra	o-	no	men-	dhung	
·	·	·	·	·	·	·	·	·	·	·	·	·	·	·	·	·
Lin-tang	su-	me-	bar	pa-	ting	ga-	le-	byar	O-ra	o-	no	men-	dhung			
·	·	·	·	·	·	·	·	·	·	·	·	·	·	·	·	·
Lin-	tang	su-	me-	bar	pa-	ting	ga-	le-	byar-	me-	go	o-	ra	o-	no	men-
·	·	·	·	·	·	·	·	·	·	·	·	·	·	·	·	·
Rem-bu	la-	ne	nge-	glo	sak	dhu-	wu-	ring	gu-	nung	Sa-	sat	si-	ni-	wo-	ko
6	6	6	·	·	·	·	·	·	·	·	·	·	·	·	·	·
Rem-bu	rem-bu	la-	ne	nge-	glo	sak	dhu-	wu-	ring	gu-	nung	Sa-	sat	si-	ni-	wo-
·	·	·	·	·	·	·	·	·	·	·	·	·	·	·	·	·
Rem-bu	la-	ne	nge-	glo	sak	dhu-	wu-	ring	gu-	nung	Sa-	sat	si-	ni-	wo-	ko

$\cdot \quad 2 \quad 2 \quad 2 \quad 5 \quad \cdot \quad 7 \quad 5 \quad 6 \quad 3 \quad 2 \quad 3 \quad 5$
 $\overline{\cdot 6} \quad \overline{\cdot 6} \quad \overline{\cdot 2} \quad \overline{\cdot 5} \quad \overline{\cdot 5} \quad \overline{\cdot 5} \quad \overline{\cdot 5} \quad \overline{\cdot 5} \quad \overline{\cdot 7} \quad \overline{\cdot 6} \quad \overline{\cdot 5} \quad \overline{\cdot 7} \quad \overline{\cdot 6} \quad \overline{\cdot 5}$
 Lin-tang se-wu po-dho se-bo lin-tang se-wu po-dho se-bo Ka-ton en-dah we-ngi se-pi

$\overline{\cdot 2} \quad \overline{\cdot 2} \quad \overline{\cdot 5} \quad \overline{\cdot 7} \quad \overline{\cdot 3} \quad \overline{\cdot 3} \quad \overline{\cdot 7} \quad \overline{\cdot 7} \quad \overline{\cdot 3} \quad \overline{\cdot 5} \quad \overline{\cdot 3} \quad \overline{\cdot 2} \quad \overline{\cdot 1} \quad \overline{\cdot 1} \quad \overline{\cdot 1} \quad \overline{\cdot 1} \quad \overline{\cdot 3} \quad \overline{\cdot 2} \quad \overline{\cdot 1} \quad \overline{\cdot 2} \quad \overline{\cdot 3} \quad \overline{\cdot 1}$
 Lin-tang se-wu po-dho se-bo lin-tang se-wu po-dho se-bo Ka-ton en-dah we-ngi se-pi

$\cdot \quad \cdot \quad 2 \quad 2 \quad \cdot \quad \overline{21} \quad \overline{5} \quad \overline{7} \quad \cdot \quad 7 \quad 7 \quad \overline{2} \quad \overline{3} \quad \overline{5} \quad \overline{6} \quad \overline{\cdot 5} \quad \overline{\cdot 5} \quad \overline{\cdot 5} \quad \overline{\cdot 5} \quad \overline{\cdot 7} \quad \overline{\cdot 6} \quad \overline{\cdot 5} \quad \overline{\cdot 7} \quad \overline{\cdot 6} \quad \overline{\cdot 5}$
 Lin-tang se-wu po-dho se-bo po-dho se-bo Ka-ton en-dah we-ngi se-pi

$\cdot \quad 5 \quad 3 \quad 2 \quad 1 \quad 2 \quad 3 \quad 5$
 $\cdot \quad 1 \quad \cdot \quad 2 \quad \cdot \quad \overline{3} \quad \overline{\cdot 5} \quad \overline{2} \quad \cdot \quad \cdot \quad 1 \quad 2 \quad 7 \quad \overline{6} \quad \overline{7} \quad \overline{6} \quad \overline{5}$
 Nyo-to a-gung pang-wa-sa-ning Gus-ti

$5 \quad 5 \quad \cdot \quad \cdot \quad \cdot \quad \overline{57} \quad \overline{6} \quad \overline{6} \quad \overline{6} \quad \cdot \quad \cdot \quad 5 \quad 3 \quad \overline{25} \quad 3$
 Nyo-to a-gung pang-wa-sa-ning Gus-ti

$\cdot \quad \cdot \quad 2 \quad 2 \quad \cdot \quad \overline{34} \quad \overline{67} \quad \overline{2} \quad \overline{2} \quad \overline{2} \quad \cdot \quad \cdot \quad 7 \quad 2 \quad \overline{32} \quad 7$
 Nyo-to a-gung pang-wa-sa-ning Gus-ti

return to umpak: $325 \quad 2356 \quad 72 \cdot 3 \quad 2765$

Kendhangan for *Ketawang Lintang*

Umpak/Sesegan (Ketawang Yogya style, Irama I)

2 3 2 5 2 3 5 $\hat{6}$ 7 2 · 3 2 7 6 (5)
 · t p b · t p · p b · \check{t} p p p b

Transition to Lagu in Irama II

2 3 2 5 2 3 5 $\hat{6}$ 7 2 · $\check{3}$ 2 7 6 (5)
 · t p b · t p · p p p b °°° p p b p b

Lagu (Ketawang Solo style, Irama II, 3 times)

2 7 6 5 2 7 6 $\hat{5}$
 k k k k k \overline{kt} p b · p · p \overline{kp} b · p
 · 6 7 $\check{2}$ 6 5 4 (2)
 p b p b · p b p \overline{p} b · p b \overline{kt} p b

Transition to Sesegan

· 5 3 $\check{2}$ 1 2 3 (2)
 k k k k k \overline{kt} p b · p · p · p \overline{pp} b

Suwuk (Yogya style)

2 3 2 5 2 3 5 $\hat{6}$ 7 2 · 3 2 7 6 (5)
 · t p b p \overline{tt} p \overline{tt} b p \overline{tt} b \overline{tt} p \overline{pp} ·

ESSAY

Recipe for an Independent Gamelan Group

by Barbara Benary

Posted on Indonesian Performing Arts—the gamelan listserv hosted by Dartmouth College—on 24 February 1996.

To any and all readers of this list: I just read notes from Pershall Becker in Cincinnati and Andy McGraw in Kansas City expressing a shade of despair over the prospect of starting up a gamelan group in their cities. Well, groups come and go in this country, even when anchored to the illusory security of an academic institution, but there's no harm in trying to get one in gear. Be the first in your state! In fact, independent gamelan groups have a few little advantages, all in all, and a couple, like my group, have managed to stay active for as long as twenty years. For those who want to take the plunge, here's my thoughts on how to get going, based on what I know of present American groups:

1. Get instruments. Either your own, or access to an existing set.

You may decide to purchase Indonesian-made instruments, new or second-hand. Recently some iron sets have been imported which are less expensive than bronze and sound quite good. Or you can make a home-made set out of iron or aluminum or brass, or some mixture thereof. To my knowledge no one is commercially producing gamelan instruments right now in this country, but there are a few makers around (myself, Daniel Schmidt in California, Dennis Murphy in Vermont, to name a few) who would be happy to advise you on a do-it-yourself project. You may be able to make an arrangement with an individual or institution that owns an authentic gamelan set. If your city

Barbara Benary (1946–2019) was a composer, ethnomusicologist, and instrument builder. Benary built her first set of gamelan instruments in 1973, and was later the co-founder (with Philip Corner and Daniel Goode) of Gamelan Son of Lion, an independent gamelan composers' collective. She also constructed more than five other Central Javanese- and Balinese-style ensembles, including the instruments of Gamelan Encantada in Albuquerque, New Mexico. As artistic director of Gamelan Son of Lion for over four decades, Benary led the group in regular performances in the greater New York area, and arranged international tours of North America, New Zealand, Eastern Europe, and Indonesia.



has an Indonesian consulate, they may have instruments not yet being put to good use. Sometimes colleges purchase instruments and then they fall into disuse when the purchasing professor retires or the college runs out of funding for a teacher; sometimes the percussion teacher may know where gamelan instruments are to be found. Or there may be private individuals or collectors or museums in your area who have purchased instruments but have not yet thought of putting them to use. In these cases it is a matter of negotiating access; the instruments' owner may be happy to have some concerts in exchange for their use.

2. Get musicians.

Invite friends. If you have a circle of musician friends where you live, this is a good place to start. The advantage of community groups is that of stable membership. People are less likely to quit during exam time or graduate and disappear. If instruments can be housed in someone's home,

you'll have rent-free rehearsal space. There have been gamelan groups with a single organizer, but there is more likelihood of group longevity if the organizing effort is shared among two or more people. (It can get exhausting to do it by yourself.)

Recruit strangers. There's nothing like a public performance, even a trial one or a casual demo at the local library, to draw the interest of available people in the community. Likely candidates include: ethnomusicologists, Asian travelers, Asians, percussionists, composers, performing musicians with broad curiosity. Try posting notices or advertisements at music stores, local colleges, community music schools, etc.

3. Get a repertoire and/or teacher: either yourself, or a qualified outsider.

You may have the background to lead a group, either from having studied with a gamelan teacher or played in a group. Or you may be a very good transcriber who can make arrangements from recordings. There is an increasing amount of repertoire available in transcription of some sort. The American Gamelan Institute is a good place to begin looking. Contact Jody Diamond or the leader of a gamelan group with similar instrumentation for repertoire exchange. (See the directory of gamelan in North America at <http://www.gamelan.org>). If you are a composer or have composers in your group, you can of course generate your own repertoire.

Find a teacher. There is a scattering of Indonesian teachers around the country, and some experienced American leaders too. They can be invited for a residency or workshop to kickstart the group into action, or if you have the means, you can invite them to come and teach periodically. Check the resources mentioned above for leads.

4. Set up your form of organization and financial identity.

The organization: Most independent gamelan function as a club, for the pursuit of learning and experience of sharing the music. Some groups require dues for membership, and generally use such funds to invite guest teachers. Others raise funds for teachers through performing fees. Yet others pay their own players for performing and do not hire a teacher. The financial format can be decided once a quorum of enthusiastic people is assembled. Get a legal identity. This helps you handle cash flow and presentations. A number of independent groups that have been in existence for some time have incorporated as not-for-profit corporations. This enables one to have an independent bank account, tax-free status, and access to various kinds of public funding: federal, state, city and private. Or you might find an existing nonprofit to act as the ensemble's umbrella. If a member of the group belongs to a college, he or she may be able to use the institution as a cover organization for the group.

5. Play and perform as much as you can. ▶



The instruments of Gamelan Son of Lion in their rehearsal/concert space in New York City, December 2018. Photos: J. Diamond.

SCORE

Mostly Slendro Passacaglia

by Barbara Benary

Contributors and Editors

BB Barbara Benary
JA Jay Arms
JD Jim Dalton
jd jody diamond

Contents

Notes (JA)
Gamelan Notation (JA)
Clarinet and Suling Notation (JD)
Saron Part (JA)
Original Score (BB)

Online

Recording of *Mostly Slendro Passacaglia*
www.gamelan.org/balungan
All six volumes of Benary's scores for gamelan:
www.gamelan.org/composers/benary



Barbara Benary, circa 1979. Photo: *Gamelan in the New World*, Folkways Records LP-31313.

Notes

Mostly Slendro Passacaglia is a composition for gamelan instruments in slendro and pelog with clarinet and suling. It was composed by Barbara Benary in 1993 as part of her wayang kulit theater piece *Karna: A Shadow Puppet Opera*. This piece combines slendro and pelog to create a composite scale and unusual harmonic framework. It takes the form of a *passacaglia*, an eighteenth-century musical form characterized by a repeating ground-bass ostinato in triple meter. The original score and notes, included here, is from *Gamelan Works Volume 4: Seven Pieces in Mixed Tuning: Slendro and Pelog* (Benary 1994: 5–9).

Structure of the Composition

Mostly Slendro Passacaglia has three formal sections, marked A, B, and C. Sections A and B alternate, each played twice (i.e. AABB). Section C is a coda, played at the end of the piece.

Benary employs a structural process involving what she describes as a cycle of fifths, in this case what the Javanese call *kempyung*, harmonic intervals made of two tones in slendro that are two scale degrees apart. In the progression from one *kempyung* to the next, shown in Figure 1, each pair of notes contains a tone from the previous pair. The progression is cyclical and occurs twice in Section A. Section B starts with the same pair, but moves through the sequence backwards, in retrograde order.

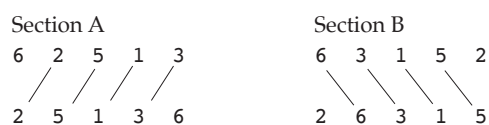

Figure 1. Progression of *kempyung* in the two sections of *Mostly Slendro Passacaglia*

Benary frequently uses this kind of process-based structure in other pieces, such as *Macramé* (1976), *Hells Bells* (1979), and *Hot Rolled Steel* (1986), in which the process is the focal point of the composition. In *Mostly Slendro Passacaglia*, however, the process of “*kempyung* modulation,” as Benary calls it, serves as a foundation for additional harmonic and melodic elaboration, taking the role of the ground-bass characteristic of the eighteenth-century *passacaglia* from which the piece takes its name.

Instrumentation and Notation

Mostly Slendro Passacaglia is scored for a minimum of six gamelan instruments: peking, saron, two demung, slenthem, and pitched gongs, plus two instruments that play melodic obbligati; other instruments may be added or substituted. Benary suggests possibly replacing the demung parts with gender, or adding more balungan instruments to the Demung I part. The two obbligati parts are for suling and “slendro clarinet.” The latter is a custom-made instrument, tuned to Gamelan Son of Lion’s slendro scale, with a body of PVC pipe with the addition of a standard clarinet bell and mouthpiece; it was originally commissioned by Daniel Goode and built by Steven Silverstein.

The gamelan score is in Kapatihan cipher notation. The notation puts the strong beat the beginning of each measure. This is sometimes referred to as “front-weighting,” in contrast to the convention in gamelan notation of “end-weighting,” or placing the strong beat at the end. Benary shows the slendro and pelog pitches together on a single line; pelog notes are identified with “p” above the cipher, while all other notes are slendro. The obbligati parts use staff notation. Benary includes a scale that corresponds to the gamelan pitches to assist the performers of the obbligato parts.

Most players will need both a slendro and pelog instrument, so some of the instruments can be set up with the slendro instrument in front of the player and the pelog instrument behind it, sometimes raised up, like on two pieces of wood.

Order of Entry and Performance Practice

The piece begins with entrances staggered in the following order:

- A Demung II and Slenthem
- A' Demung I¹
- B Saron, doubling Demung I
- B' Saron (playing its own part), Peking

Gongs, other gamelan instruments, and clarinet enter at A on the second cycle of the AABB form. The suling enters near the end of the clarinet melody, overlapping slightly.

The slenthem has two notated variations, and the player may freely switch between them. Once the obbligato instruments are playing, the gamelan should provide a constant texture with no dynamic or tempo variations. After repeating the AABB form as many times as desired, Section C is played directly after B', with a slight ritard near the end, and a pause before the final gong.

Mostly Slendro Passacaglia on Other Gamelan

Mostly Slendro Passacaglia was composed specifically for Gamelan Son of Lion, based on the tuning and physical characteristics of those instruments. To play this piece on another gamelan, it is important to understand Gamelan Son of Lion’s tuning and instruments when configuring the

parts for a gamelan that is likely to be tuned differently.

Tuning

As the title of the piece implies, *Mostly Slendro Passacaglia* uses all five slendro tones, plus two from pelog (3 and 7). In sequence from low to high, the composite scale for *Mostly Slendro Passacaglia* must be: S1, S2, P3, S3, P4/S5, 6, and P7. While the overall arrangement of scale tones is more important than their absolute pitch, Benary composed these melodies with Gamelan Son of Lion’s interval sizes in mind, some of which are harmonically meaningful in the context of this piece. The interval between pelog 7 and slendro 1, for example, is about 55 cents on Gamelan Son of Lion and serves as a kind of “leading tone,” whereas if this interval is wider on another gamelan it will not serve that same function.

In Gamelan Son of Lion’s tuning 6 is the same in slendro and pelog (*tumbuk*), and slendro 5 is the same as pelog 4. Without this configuration, it may not be possible to play this piece since that difference may affect the composite scale prescribed above. A gamelan with *tumbuk* 2 would need to adjust the parts to always play slendro 6 and not use it interchangeably with pelog 6. A gamelan with *tumbuk* 3, however, would not be able to play this composition at all, because the composed melodies depend on slendro 3 sounding higher than pelog 3 (about 40 cents).

The notation also assumes that pelog 4 and slendro 5 are the same pitch, using each in different parts of the piece for ease of playing. If this equivalence is not present, it is possible to use slendro 5 exclusively and adapt the notation accordingly. These common tones are also important to the performance of this piece as they facilitate changing from one scale to the other.

If a gamelan does not have a tuning similar to Son of Lion’s, it may still be possible to create a suitable scale from available tones. Benary’s composite scale is loosely similar to a D-flat major scale with variously sized intervals (not equal tempered). There may be a way to create a similar scalar hierarchy with tones from another gamelan. Experimentation is encouraged!

Instrumentation

For the pitched gong part, Gamelan Son of Lion uses a set of instruments called “key gongs,” based on a design by composer and instrument builder Daniel Schmidt.² These instruments are large aluminum slabs suspended over long resonators and serve the same function as gong or kempul. *Mostly Slendro Passacaglia* requires the full range of slendro pitches in the lower register, from low 2 to high 1 (23561̇). A Javanese gamelan can use kempul and gong suwukan or gong ageng for this part. For the obbligato instruments, Benary suggests that string instruments, such as rebab, erhu, or violin could be used instead of the wind instruments notated in the score, as long as they can play in tune with the gamelan.

Arranging the Saron Part

The balungan instruments of Gamelan Son of Lion have small keys and a short sustain. These characteristics allowed Benary to write the saron part for one player to perform with two mallets without damping. This playing technique could be problematic for more resonant instruments. One possible solution is to play the saron part on a different instrument, such as a bonang panerus (with pots arranged to include the pelog pitches), gambang, or a celempung with minor tuning adjustments.

For this *Balungan* edition of *Mostly Slendro Passacaglia*, I have created an arrangement of the saron part in which the notated part is divided between two players in imbal-like fashion. In order to replicate Benary's saron part, the two parts could not be evenly divided rhythmically. This part assumes the same tumbuk and low-to-high pitch organization as in Gamelan Son of Lion. The Saron I player will use only the slendro saron, while the musician playing Saron II will need to use both slendro and pelog instruments. ▶

Endnotes

1. In the recording of this piece, the Demung I played a sparser version of the written part in A', adding the rest of the notated part later in the B section. See, *Gamelan Son of Lion*, New Gamelan/New York (GSOL Records, GSOL CD-1, 1995).

2. These instruments serve the same function as gong and kempul for many other American-made gamelan ensembles, such as the Berkeley Gamelan, Gamelan Pacifica, Gamelan Son of Lion, and the Diamond Bridge.

Notation Key: approximation of Son of Lion tuning

The notation key consists of four staves of music in treble clef, each with a key signature of one flat (B-flat). The notes are as follows:

- Slendro:** Notes are B-flat, C, D, E, F, G. Fingerings below are 6, 1, 2, 3, 5, 6, i.
- Pelog:** Notes are C, D, E, F, G, A, B. Fingerings below are 1, 2, 3, 4, 5, 6, 7.
- Composite Slendro/Pelog:** Notes are B-flat, C, D, E, F, G, A, B. Fingerings below are 1, 1, 2, 2, 3, 3, 4, 5, 6, 7, with a 5 and 6 below the 4 and 5 respectively. Pitches are marked with 'P' below notes C, D, E, F, G, A, B.
- Scale for Mostly Slendro Passacaglia:** Notes are B-flat, C, D, E, F, G, A, B. Fingerings below are 1, 2, 3, 3, 4, 6, 7, with a 5 and 6 below the 4 and 6 respectively. Pitches are marked with 'P' below notes C, D, E, F, G, A, B.

Mostly Slendro Passacaglia, by Barbara Benary (1994)

	A					TO A OR B					TO C															
Peking	6	2	3	5	6	3	5	i	7	6	5	3	3	i	6	5	3	2	3	5	6	6	3	5		
Saron	6	2	3	5	6	2	3	5	6	2	3	5	6	5	1	2	3	5	6	3	6	3	3	6	3	3
Demung I	6	6	6	6	6	i	5	5	5	5	5	3	3	3	3	3	3	2	3	5	3	3	3	3		
Demung II	2	2	2	2	2	2	2	2	2	2	2	2	1	1	1	1	1	1	1	6	6	6	6	6	6	
Slenthem	2	2	2	2	2	2	2	2	2	2	2	2	i	1	1	1	1	1	1	6	6	6	6	6	6	
Sl. variation	2	2	2	2	2	2	2	2	2	2	2	2	i	1	1	1	1	1	1	6	6	6	6	6	6	
Gongs	2	2	2	2	2	2	2	2	2	2	2	2	i	i	i	i	i	i	i	6	6	6	6	6	6	
Peking	2	6	3	3	2	6	6	3	3	6	3	5	3	i	6	5	3	i	2	i	7	5	3	5		
Saron	2	6	3	3	2	6	6	3	3	6	3	5	3	i	6	5	3	i	2	i	7	5	3	5		
Demung I	6	6	6	6	6	35	6	6	6	6	6	35	i	i	5	6	i	7	5	6	6	6	6			
Demung II	2	2	2	2	2	2	2	2	2	2	2	2	3	3	3	3	3	3	5	5	5	5	5	5		
Slenthem	2	2	2	2	2	2	2	2	2	2	2	2	6	6	6	6	6	6	6	5	5	5	5	5	5	
Sl. variation	2	2	2	2	2	2	2	2	2	2	2	2	6	6	6	6	6	6	6	5	5	5	5	5	5	
Gongs	2	2	2	2	2	2	2	2	2	2	2	2	6	6	6	6	6	6	6	5	5	5	5	5	5	

Form: [AABB] min. 4x, C 1x.

Entrances are staggered for the first cycle. A: Slenthem, Demung 2/A: Demung I/B: Saron, doubling Demung I/B: Saron, Peking/Gongs, other gamelan instruments, and clarinet enters on the second cycle of the AABB form. (See notes about optional clarinet and stuling.)

C (Coda)

Peking	6 2 3 5 6 3	5 ^p i 7 6 5 3	5 1 2 3 5 6	3 ⁱ 1 6 5 3 2	3 5 6 6 3 3	. . . 2 . . .
Saron	6235 6235 6236	^p 4i76 ^p 4i76 ^p 4i76	5123 5123 5125	3i65 3i65 3i65	^p 3633 ^p 6633 ^p 6335	. . . 6/2 . . .
Demung I	6 . 6 6 6 i	5 . 5 5 5 5 3	5 . 5 5 5 5 6	3 . 3 3 3 3 2	^p 3 5 3 . 3 5	. . . 6 . . .
Demung II	2 . 2 . 2 .	2 . 2 . 2 .	1 . 1 . 1 .	1 . 1 . 1 .	6 . 6 . 6 2 . . .
Slenthem	2 . . . 6 .	5 . . . 7 .	i . 1 . . 5	3 . . . 5 .	6 . 6 2 . . .
	2	5	i	3	6	2

slowing..... tremolo to quiet

Alternate saron part, by Jay Arms

A

Saron I	6.3. 6.3. 6.3.	5i. . . 5i. . .	5.2. 5.2. 5.2.	3.6. 3.6. 3.6.	3.3. 6.3. 6.3.
Saron II	.2.5 .2.5 .2.6	^{pp} .76 ^{pp} .76 ^{pp} .76	.1.3 .1.3 .1.5	.i.5 .i.5 .i.5	^p .6.3 ^p .6.3 ^p .6.3

B

Saron I	2.3. 2.3. 2.3.	6.3. 6.3. 6.3.	3.6. 3.6. 3.6.	1.3. .i3. .i3.	2i. . . 2i. . .	To C
Saron II	^p .6.3 ^p .6.3 ^p .6.3	^p .3.6 ^p .3.6 ^p .3.4	.i.5 .i.5 .i.5.	^p .i.4 ^p .3.4 ^p 3.4	^{pp} .74 ^{pp} .74 ^p .3.3	^{pp} 2i ^{pp} 2i. . . 2.3.

C (Coda)

Saron I	6.3. 6.3. 6.3.	5i. . . 5i. . .	5.2. 5.2. 5.2.	3.6. 3.6. 3.6.	3.3. 6.3. 6.3. 2
Saron II	.2.5 .2.5 .2.6	^{pp} .76 ^{pp} .76 ^{pp} .76	.1.3 .1.3 .1.5	.i.5 .i.5 .i.5	^p .6.3 ^p .6.3 ^{pp} .34 6

Mostly Slendro Passacaglia

Barbara Benary

Finale notation: Jim Dalton

Hi F - overblow 6

Hi G \flat - overblow 3

L = leg note

(clarinet solo)

A1 5 A2 5 B1 5 B2 3 (cue)

suling solo

L A2 B1 B2 L A1 Duet A2 B1 B2 A1 3

Mostly Slendro Passacaglia

Barbara Benary
Finale notation: Jim Dalton

A1

A2

B1 *

B2

A1 ** A2 5 B1 5 B2 5

A1

A2

B1 B2

A1

* note: if is impossible, substitute ** or try

About the Tunings and Notation

This set of seven pieces was written between 1980 and 1994. Their common denominator is that they each require the simultaneous use of slendro and pelog tunings.

Generally each player plays a pair of instruments arranged as a double keyboard, although for a few pieces the tunings are kept apart and played by different persons.

In those pieces where process is the primary focus, the pitch relationships of the two tunings is less relevant. However a few of the pieces are pitch-specific, and meant to be played on a set of instruments whose tunings approximate those of Gamelan Son of Lion, for whom they were written. *Woodstock*, for example, is the piece which is most pitch-specific and represents one end of the spectrum. *Yudishthira's Quartet*, on the other end of the spectrum, is based on randomness and any pitches at all will do.

For all other pieces the primary necessity is that the general relationships of the two scales resemble that of the chart below. In sequence from lowest to highest the pitches should be: slendro 1, pelog 1, slendro 2, pelog 2, pelog 3, then slendro 3. Tumbuk 6 (common tone on both scales) is desirable, and in some pieces a second "tumbuk": slendro 5 = pelog 4. Diatonic approximations are given for Gamelan Son of Lion's tunings in the charts below, but the intervallic relationships of the slendro and pelog are more important than the range relationship to the diatonic models.

If the available gamelan set has pitch relationships other than these, consult the introduction to each individual piece to determine if it will work.

The following notations are in number (cipher) form. As they are not Indonesian pieces, the convention of end-beat stress is not used. Unless otherwise indicated, assume downbeats, as in western music. Standard staff notation is also included for obligato instruments.

The diagram illustrates the relationship between Slendro and Pelog scales. It features two musical staves at the top. The left staff, labeled 'SLENDRO', shows a scale of six notes: b, b, b, b, b, b. The right staff, labeled 'pelog', shows a scale of seven notes: ., ., ., #, ., ., . Below these staves are four horizontal lines representing scales. The first line, labeled 'PELOG', has seven notes numbered 1 through 7. The second line, labeled 'PIANO', shows a diatonic scale: C, C#, D, D#, E, F, F#, G, G#, A, A#, B, C, C#. The third line, labeled 'SLENDRO', has seven notes numbered 1, 2, 3, 5, 6, i.

MOSTLY SLENDRO PASSACAGLIA

Orchestration and Notation:

For a minimum of 6 players: key-gongs (gong & kempul), slentem, two demung, one saron, one peking. Additions and substitutions: gender and/or gender panerus can substitute for the two demung players, or supplement them. An additional pair of saron may double the demung 1 line. Two obbligato parts are a desirable addition, but optional.

Each player uses a pair of like instruments in slendro and pelog. Since the piece is mostly slendro, it is suggested that the slendro keyboard be placed closest to the player and the pelog positioned behind it (rather like the black keys on a conventional keyboard). Saron 1 (solo player) will need two mallets.

Slendro and pelog parts are notated in a single line. Notes with a "p" above them are on the pelog keyboard; all others are slendro.

Obbligato parts:

Two melodic, non-keyboard instruments are required, preferably of different timbre and range. Gamelan Son of Lion used a suling and a custom-made slendro clarinet. A bowed string instrument could substitute (rebab or erh-hu for example).

A composed notation is provided for the obbligato lines. These are in western staff notation, following the pitch approximation chart in the introduction to this volume. Using these composed lines the piece has a finite length of four repeats (2A + 2B) plus coda. Gamelan moves to the coda (C) when the obbligato instruments are holding their final note.

If indeterminate length is desired, the obbligato players may instead improvise their lines, taking turns according to a pre-arranged sequence.

Length and sequence of sections:

The general formula for the piece is 2x (A) and 2x (B), and this sequence is repeated a pre-arranged number of times - four if the composed obligatos are used. The coda (C) is played only once.

Order of initial entry:

Staggered entrances throughout the first two (A) & (B) sections. First (A): slentem and demung 2. Second (A) add demung 1. First (B) add saron 1 doubling demung 1 line. Second (B) saron 1 moves to its solo line and peking enters.

On the repeat of the piece add keygongs and any other doubling instruments. Slentem may use its variation line ad lib. The clarinet obbligato enters at this point.

Gamelan provides a constant texture with no dynamic or tempo variations from here until the coda, where there is a moderate slowdown to the final gong.

MOSTLY SLENDRO PASSACAGLIA

(A)

<u>peking:</u>	6 2	3 5	6 3	5 $\dot{1}$	$\overset{p}{7}$ 6	5 3
<u>saron 1:</u>	6235	6235	6236	$\overset{p}{4}$ $\overset{p}{1}$ $\overset{p}{7}$ 6	$\overset{p}{4}$ $\overset{p}{1}$ $\overset{p}{7}$ 6	$\overset{p}{4}$ $\overset{p}{1}$ $\overset{p}{7}$ 6
<u>demung 1:</u>	6 $\overline{.6}$	6 6	6 $\dot{1}$	5 $\overline{.5}$	5 5	5 3
<u>demung 2:</u>	2 .	2 .	2 .	2 .	2 .	2 .
<u>slentem:</u>	2 .	. .	6 .	5 .	. .	$\overset{p}{7}$.
<u>slentem variation:</u>	2 .	. .	2 6	5 .	. 5	. $\overset{p}{7}$
<u>keygongs:</u>	(2) 6			5		

<u>peking:</u>	5 1	2 3	5 6	3 $\dot{1}$	6 5	3 2	3 5	6 $\overset{p}{6}$	$\overset{p}{3}$ 5
<u>saron 1:</u>	5123	5123	5125	3 $\dot{1}$ 65	3 $\dot{1}$ 65	3 $\dot{1}$ 65	3633	$\overset{p}{6}$ 633	$\overset{p}{6}$ 633
<u>demung 1:</u>	5 $\overline{.5}$	5 5	5 6	3 $\overline{.3}$	3 3	3 2	3 5	p3 .	. 35
<u>demung 2:</u>	1 .	1 .	1 .	1 .	1 .	1 .	6 .	6 .	6 .
<u>slentem:</u>	$\dot{1}$.	1 .	5 .	3 .	. .	5 .	6 .	6 .	. .
<u>sl. var.:</u>	$\dot{1}$.	1 .	. 5	3 .	. 2	3 5	6 .	6 .	. .
<u>keygongs:</u>	1			3			6		

(B)

<u>peking</u>	2 6	3 $\overset{p}{3}$	2 6	6 $\overset{p}{3}$	3 6	$\overset{p}{3}$ 5	3 $\dot{1}$	6 5	3 $\dot{1}$
<u>saron 1:</u>	$\overset{p}{2}$ $\overset{p}{6}$ 33	$\overset{p}{2}$ $\overset{p}{6}$ 33	$\overset{p}{2}$ $\overset{p}{6}$ 33	$\overset{p}{6}$ 336	$\overset{p}{6}$ 336	$\overset{p}{6}$ 335	3 $\dot{1}$ 65	3 $\dot{1}$ 65	356 $\dot{1}$
<u>demung 1:</u>	6 $\overline{.6}$	6 6	6 $\overline{35}$	6 $\overline{.6}$	6 $\dot{1}$	7 6	$\dot{1}$ $\overline{.1}$	$\dot{1}$ 5	6 $\dot{1}$
<u>demung 2:</u>	2 .	2 .	2 .	$\overset{p}{3}$.	$\overset{p}{3}$.	$\overset{p}{3}$.	3 .	3 .	3 .
<u>slentem</u>	2 .	. .	2 .	6 .	6 .	5 .	3 .	. .	3 .
<u>sl.var.</u>	2 .	. .	2 .	6 .	6 .	. 5	3 .	. .	$\overset{p}{3}$ 2
<u>keygongs</u>	(2) 6			6			3		

Mixed Tuning 6

		to (B)	to (A) or (C)
<u>peking</u>	1 $\dot{1}$ 3 5 3 $\dot{1}$	2 $\dot{1}$ $\overset{p}{7}$ 5 3 $\overset{p}{3}$	2 $\dot{1}$ $\overset{p}{7}$ 5 3 5
<u>saron 1:</u>	$\dot{1}$ 135 $\overset{p}{3}$ 135 $\overset{p}{3}$ 135	$\overset{p}{2}$ 175 $\overset{p}{2}$ 175 $\overset{p}{3}$ 323	$\overset{p}{2}$ 175 $\overset{p}{2}$ 175 $\overset{p}{3}$ 335
<u>demung 1:</u>	7 5 $\dot{1}$. . $\dot{1}$	$\overset{p}{7}$ 2 $\overset{p}{7}$. . $\overline{65}$	$\overset{p}{7}$ 2 $\overset{p}{7}$. . $\overline{65}$
<u>demung 2:</u>	5 . 5 . 5 .	5 . 5 . 5 .	5 . 5 . 5 .
<u>slentem</u>	1 . $\dot{1}$. 6 .	5 . . . 3 $\overset{p}{3}$	5 . . . 3 $\overset{p}{3}$
<u>sl. var.</u>	1 . $\dot{1}$. . 6	5 . 2 5 3 $\overset{p}{3}$	5 . 2 5 3 $\overset{p}{3}$
<u>keygongs</u>	1	5	

(C)

<u>peking:</u>	6 2 3 5 6 3	5 $\dot{1}$ $\overset{p}{7}$ 6 5 3	5 1 2 3 5 6
<u>saron 1:</u>	6235 6235 6236	$\overset{p}{4}$ 176 $\overset{p}{4}$ 176 $\overset{p}{4}$ 176	5123 5123 5125
<u>demung 1:</u>	6 $\overline{.6}$ 6 6 6 $\dot{1}$	5 $\overline{.5}$ 5 5 5 3	5 $\overline{.5}$ 5 5 5 6
<u>demung 2:</u>	2 . 2 . 2 .	2 . 2 . 2 .	1 . 1 . 1 .
<u>slentem:</u>	2 . . . 6 .	5 . . . $\dot{7}$.	$\dot{1}$. 1 . . 5
<u>keygongs:</u>	② G	5	$\dot{1}$ 1

			(all tremolo)
<u>peking:</u>	3 $\dot{1}$ 6 5 3 2	3 5 6 $\overset{p}{6}$ 3 $\overset{p}{3}$. . 2 . . .
<u>saron 1:</u>	3 $\dot{1}$ 65 3 $\dot{1}$ 65 3 $\dot{1}$ 65	3633 $\overset{p}{6}$ 633 $\overset{p}{6}$ 335	. . 6 . . 2 . . .
<u>demung 1:</u>	3 $\overline{.3}$ 3 3 3 2	3 5 $\overset{p}{3}$. 3 5	. . 6 . . .
<u>demung 2:</u>	1 . 1 . 1 .	$\overset{p}{6}$. $\overset{p}{6}$. $\overset{p}{6}$.	. . 2 . . .
<u>slentem:</u>	3 . . . 5 .	6 . $\overset{p}{6}$ 2 . . .
<u>keygongs:</u>	3	6	② G

ritard -----

Mixed Tuning 7



Mostly Slendro Passacaglia - slendro suling

clarinet solo

H: F = overblow 6
 H: G^b = overblow 3
 L = leg note

The musical score is written on ten staves. The first staff shows the clarinet solo with notes marked A¹, A², B¹, and B², and a triplet of 3 notes. The second staff is labeled '(sue)' and 'suling solo' with a note marked A¹. The third staff contains a melodic line with a 'leg note' (L) marking. The fourth staff has a note marked A². The fifth staff has a note marked B¹. The sixth staff has a note marked B². The seventh staff is labeled 'A1 DUET'. The eighth staff has a note marked A². The ninth staff has a note marked B¹. The tenth staff has a note marked A¹ and a triplet of 3 notes. The score ends with a double bar line.

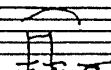
Mostly Slendro Passacaglia — clarinet in slendro+

* note: if  is impossible, substitute  or try 

INSTRUMENTS

Making Bamboo Angklung

by Barbara Benary

Introduction

The following instructions are the results of my experiments in building and tuning angklung rattles, and may be taken as guidelines for experimentation with bamboo or other materials. I am assuming the reader has a prior familiarity with these kinds of instruments and at least has seen if not actually handled them.

A single angklung, for the purpose here, refers to one unit of two to four tuned tubes—which I refer to as a “rattle”—suspended in a frame with a shared base (Figure 1). There may be two or three octaves represented on a single angklung. In this guide I will use the word “angklung” to refer to a single frame with its two or three tubes. An angklung ensemble may consist of a number of framed rattles, each tuned to a pitch chosen by the maker.

The required tools and materials for building an angklung include: seasoned bamboo, a power drill, chisels, coping saw, vise, knife, quarter-inch dowels, string, and glue (epoxy).

Choosing Bamboo

In Southeast Asia, angklung are made from bamboo stalks that have long segments of a foot or more divided by solid joints visible on the exterior as rings called “nodes.” Each rattle usually has only one segment closed by a node, which forms the closed end. The American-grown bamboo that I have found in California seems rarely to have more than nine or ten inches of length between the nodes no matter if the piece be thick or thin. It is still possible to make larger (lower pitched) angklung using such bamboo with extra nodes on the rattles. The extra nodes will not affect the sound, but it may affect the longevity of the tube.

Nodes are closest together at the base of the bamboo plant and grow increasingly further apart toward the middle of the stalk. Toward the very top they become closer again. The exterior diameter of the tube is largest at the base of the plant and decreases up to the top. The wall thickness, however, is much greater at the bottom than at the middle. This affects the pitch of a given piece

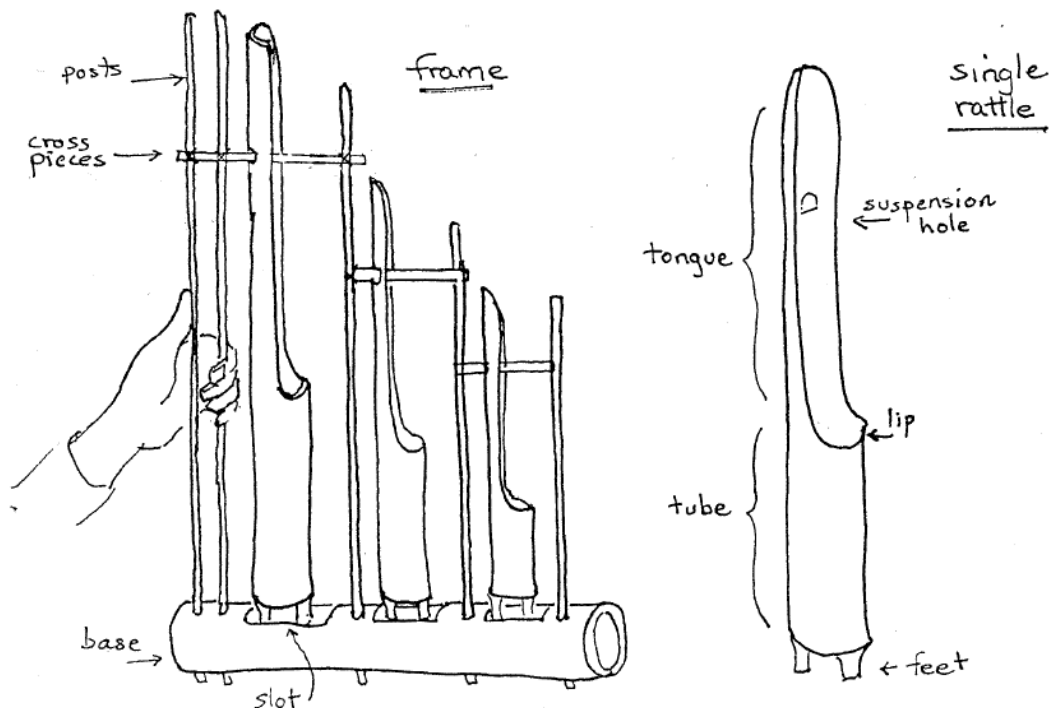

Figure 1. The parts of an angklung frame with rattles and a single rattle.

because pitch depends in part on the volume of the air space within the tube. Given two pieces of bamboo with identical diameters, one from low on the plant and one from higher, a tube made from lower one will produce a higher pitch because it will have less space for air. It is not desirable to use the bottommost part of the plant for angklung building. Save them to make a shakuhachi.

The top of the plant is also undesirable for angklung. From about the middle of the stalk on up, the nodes will show strongly marked indentations from where the leaves grew or a side branch sprouted. These nodal marks are places where splitting is likely to occur. It is better always to use a piece with no such marks.

As with wood, bamboo should be well dried before one attempts to work on it. If you hear the sound of a rifle shot in your house in the dead of night, it may not be vigilantes, but a piece of partly worked bamboo splitting on you.

When bamboo splits, it will always be in the lengthwise direction, along the grain. This characteristic is both a nuisance and an advantage. The node that is to serve as the closed end of the tube must be un-cracked. A crack at the other end, however, may be put to use if it is in the right place. But once a piece of bamboo has started to split where you don't want it to, throw it out.

CUTTING THE RATTLE

When cutting the bamboo, use a saw for cross-grain cuts (I use a coping saw) and a chisel for lengthwise splits, which is much faster than cutting downward with a saw. Always make the crosswise cut first, and then the lengthwise split. The crosswise cut will provide the terminal place for the split you make with the chisel; otherwise you have no

control over how far down your split goes.

A rattle—as I will call each note in a single frame—consists functionally of two parts: the bottom half, which I call a tube, and the top half, which I call the tongue. Each is tuned independently, so the choice of length of the piece you start with is to some extent a visual decision, as some variability is possible. The rattles generally run from about 9 inches to 2 feet in length.

Cut your bamboo to leave about three quarters of an inch below the bottom node. You need this material extending down below the node to cut the “feet” that will be inserted into the base of the instrument. It doesn't seem to matter whether the rattle ends up being right side up or upside down in relation to the way the plant grew.

Size and Length

Estimating the length of bamboo for a rattle of a desired pitch is in part a matter of trial and error. However, here are some clues. If the length of a given pitched rattle is known, the octave above needed for the other tubes (using smaller diameter bamboo) is a little more than half the length of that rattle. The octave below (using larger diameter bamboo) is a little less than twice the length.

Table 1 shows approximate pitches and measurements of some rattles I have made from American bamboo, which has a relatively thicker wall than its Southeast Asian counterparts, and some from my Thai set, which has thinner walls. The number following the note name indicates its octave. (1=middle C octave, 2=the octave above, 3=the octave above that.) All measurements are in inches.

<u>pitch</u>	<u>total length</u>	<u>tongue</u>	<u>tube</u>	<u>circumference</u>
American bamboo				
C#2	11.75	6	5.75	4.85
C#3	8	5.75	2.25	4.85
D#2	11.75	5.75	5.25	4.35
D#3	7.75	5.75	2	4
F2	12.25	7.75	4.25	4.5
F3	6.75	4.75	2	3.85
G#2	10	6.25	3.75	5
G#3	6	4	2	3.25
Thai bamboo				
D1	24	12.5	11.5	6.75
D2	15	9.5	5.5	5.25
D3	9	6.25	2.75	3.85
F1	19.25	10.5	9	6.25
F2	11.25	7	4.25	5.25
F3	7.5	5	2.5	3.5
G#1	18	9.5	8.5	6
G#2	11.25	7.5	3.75	4.85
G#3	6.5	4.5	2	3.4

Table 1. Sizes of pitched rattles in American and Thai bamboo angklung sets.

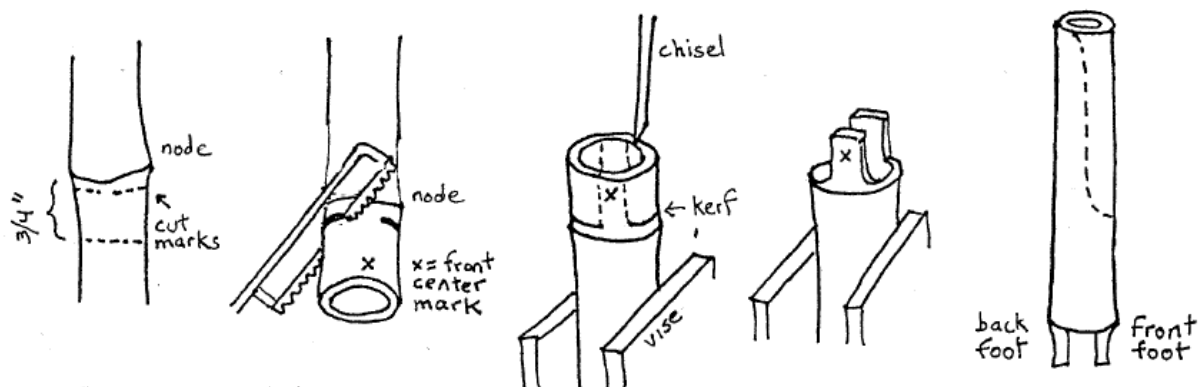

Figure 2. The steps in cutting the feet.

Cutting the Feet

It is advisable to cut the feet first (Figure 2). This will give you a place to tap when tuning the tube and tongue. There are two feet on each rattle. One faces front, the other back. By front I mean the part of the rattle out of which a slice will be cut to form the tongue. The back is the uncut part that is the tongue.

If your piece has a leaf node mark, it might be a good idea to have this node be the front-center line, so that some of it will be cut off in making the tongue, thereby leaving less material that is likely to split. The foot will function whether or not it is cut on a leaf node mark.

Make a mark where the center of the front and back foot will be. Then saw in from both sides just below the node. Saw in a third or more of the way toward the marks. Leave enough uncut material for a foot of about $\frac{1}{4}$ inch in width. It is better to cut it too wide at first; one can always take off more material later.

Then brace the piece upside down in a vise and tap down with your chisel from directly above the place where your saw kerf ends. The bamboo should split easily, and the extraneous material will fall away. If the foot ends up too wide, narrow it by sawing in a bit more and tapping off another slice. If you accidentally saw the foot off, it may be glued back in place with epoxy. It will not be structurally as sound, but the foot is not acoustically important to the sound of the rattle.

Cutting the tube and the tongue

The tube and tongue part of each rattle are tuned separately, but should end up in unison with each other. When they are in unison the rattle produces a single, amplified note.

The tube, or lower part, is tuned acoustically as a column of air: its length is the most crucial factor. Once it is cut, you can easily raise its pitch by shortening its length, but it is more difficult to lower it. The tongue works acoustically as a reed, or as half a bar. Length is one factor in determining its pitch, but the relative thickness of top and bottom can be manipulated to adjust the pitch in either direction. Because there is less flexibility in tuning the tube, it is better to cut with the tuning of that part of the rattle as a priority and later adjust the tongue to match it.

The first cut divides the piece into tongue and tube (Figure 3). The location of this cut is partly aesthetic and partly acoustic. Remember that the length of the tube part pretty much fixes its pitch, and if you cut it too short the piece will have to be used for a higher note.

Visually the proportions of tube to tongue look best at anywhere between 1:1 and 2:3. The proportion increases as the pitch gets higher: tongue longer, tube shorter. With rattles pitched below middle C, the proportion is 1:1, or in fact, the tongue may be shorter than the tube.

If you have a specific pitch in mind, it is better to overestimate the required length of the tube, and to place the first cut too high. It can always be cut down lower later to raise the pitch. Mark the position of your first cut at the front center (aligned with the front foot).

After you have identified the placement of your first cut and marked it, place the piece in the vise horizontally with the front foot facing upward. Begin your cut at the front center. Saw straight down and about halfway through the diameter.

Then trace the edges of the cut up the grain to the top of the piece, and mark the two places on top. Reposition the piece in the vise vertically. Gently tap down at the marked spots with the chisel until the bamboo cracks and half of the upper part falls away. Now you may begin fine tuning the tube and tongue.

Imperfections

Imperfections in a given piece of bamboo do not necessarily render it unusable. In some cases you can plan your building to make use of or negate certain qualities that may otherwise hinder the piece of bamboo from functioning as an *angklung*. If there is a node in the middle of the length of bamboo, for instance, you can make it the dividing point between tube and tongue, and make the first cut on the node itself. Then simply remove the middle material of this extra node with a knife.

If you have a piece of bamboo that has a good node at the foot end, but is partially split at the other end, it can still be used to create a rattle. Plan your first cut so that the partially split end will ultimately form one side of the

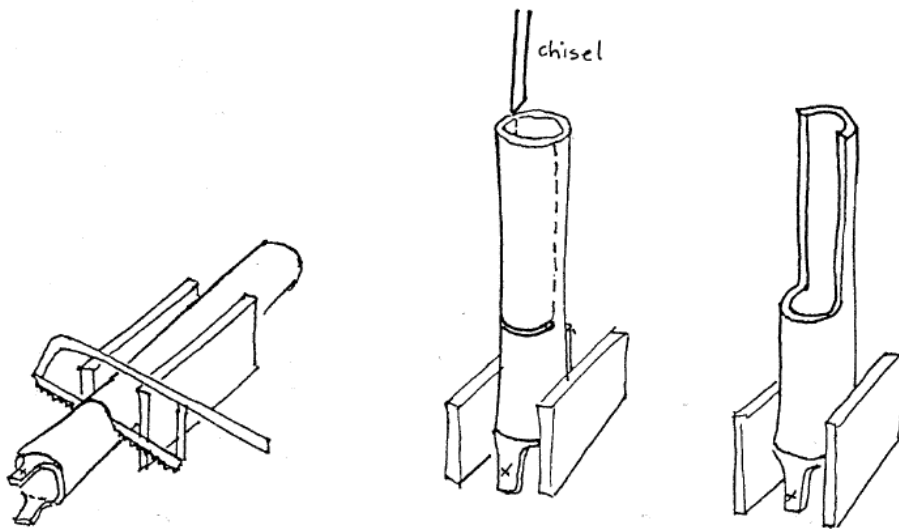

Figure 3. Cutting the tongue.

tongue. Just be careful not to exacerbate the split when cutting the feet and making the first cut.

TUNING THE RATTLE

Distinguishing Pitch

Most likely if you tap various parts of the newly cut rattle, you will hear two different pitches. One of these pitches is produced by the tube, and the other by the tongue. The first task is to figure out which is which.

Hold the rattle at a point a bit above the middle of the tongue and tap it on or between the feet. This is approximately how the instrument will work when suspended in its frame. Then try one or all of the following strategies to distinguish which pitch is coming from which part of the instrument:

While tapping, lay a finger on top of the tongue. This stifles tongue pitch and you should hear more tube pitch.

Tap alternately at the top of the tongue to hear more tongue pitch and at the lip of the tube to hear more tube pitch. Don't block the opening of the tube in order to hear more tongue pitch. Probably you won't hear anything.

After knocking all bamboo dust out of the tube, blow across the opening to hear its pitch. If the pitches you hear are within your vocal range, try singing a sliding note next to and across the tube (without blocking the opening). When you match the tube's pitch, it will resonate.

Raising Tube Pitch

To raise the pitch of the tube, cut slices off of the lip to make the tube length shorter. Make the cuts parallel, and small if you are close to the pitch you want. Chisel off each slice with a gentle tap and test the pitch again before cutting further. If you're not sure whether the tube needs to be just a little higher, wait until after the tongue is tuned to make that last slice.

If you cut the lip at the node and want to keep it there,

make your initial cut slightly above the node line. Your tube is now capped at both ends. Chisel a small hole through the top node, making a semi-closed tube whose pitch will be lower than an open tube. To raise the pitch, knock out more of the node material or, if need be, shave down the inside of the thick node walls.

There is really no going back if the tube pitch gets too high. I have tried some cut-and-paste remedies: gluing back the last slice I cut off, inserting material into the inside edge of the top opening, etc. If the epoxy holds, this material will lower the pitch a bit, but I don't recommend these measures; they all look sloppy.

Tuning the Tongue

Here one is fortunate in having a lot of leeway to either raise or lower the pitch that emerges after the initial cutting. Weight and thickness of the tongue determine its flexibility and thus its pitch. The heavier (more rigid/less flexible) the tongue is, the higher its pitch. A second factor is length. The longer the tongue is, the lower its pitch. Thus one raises the pitch by removing material from the end of the tongue and shortening it. One lowers pitch by removing material from the sides and base of the tongue, thereby lightening it and increasing its flexibility.

Raising Pitch

For gross tuning, if you are several notes too low for desired pitch, cut slices off the tip. Don't worry too much about overshooting the mark since it is easy to lower the pitch again. To fine-tune the tongue, chisel the very tip thin, particularly at the corners.

Lowering Pitch

You must remove material from the middle and base of the tongue in order to lower its pitch. Generally this is done

by chiseling strips off the sides down to the lip of the tube. Be sure to saw in before chiseling down to reduce the risk of splitting the tube as well. To fine-tune, take small slivers off the sides of the tongue, or else cut away the edge at the base. For very large rattles, you can also chisel the lower wall of the tongue to make it thinner.

Take note that when you cut the suspension hole, the pitch of the tongue will be lowered slightly on lighter pieces of bamboo.

ASSEMBLING THE ANGKLUNG

Base Tube

The tube at the base of the rattle frame functions only partially as a resonator, and does not need to be tuned. Its major purpose is to support the entire frame, and to provide the slots within which the feet of the rattles move and knock against the hard surface to generate sound.

In Balinese and Javanese angklung, the base is usually an open-ended tube of bamboo of sufficient length to allow for the spacing a movement of the two, three, or four rattles that fit in the single frame. However, the base need not even be a tube. I have an angklung set I believe to be from Thailand in which the base takes the form of a wooden canoe, and the rattle feet knock against wooden blocks set in the trough at front, rear, and middle.

In my experience, the canoe design appears to have a distinct advantage over the bamboo tube design (Figure 4). It is virtually indestructible, whereas I have found that bamboo tubes, after being drilled and chiseled in many places for the feet and frame sticks, are structurally weaker and very prone to splitting. Split base tubes give the angklung a bad sound and can't be used.

Despite this disadvantage, if you wish to construct a bamboo tube for the base, here is how to do it.

Choose a tube about the same diameter as the largest rattle that will go into the frame. In length, allow a slot for each rattle that will be about $\frac{1}{4}$ inch longer than its

diameter. Also allow about $1\frac{1}{2}$ inches of length for post holes at each end and between rattle slots. Make these spaces slightly bigger for large, low-pitched angklungs.

First mark where the postholes are to go: one at each end, and one to go between each rattle slot. Thus a two-rattle frame needs three postholes, a three-rattle frame needs four. My sturdy Thai set includes an extra posthole at the end where the largest rattle hangs, placed about an inch away from its partner. The double posts at this end enable the player to get a firmer grip on the frame.

Postholes and slots are all in a line, following the grain of the bamboo. After they are all marked, use a $\frac{1}{4}$ inch drill and put holes through for each post, and at each end of where each slot will be.

Since the posts must go entirely through the tube, next mark the emerging postholes on the opposite side of the tube and drill them. As a safety precaution to keep the drill from hitting and possibly cracking the already drilled side, place a piece of wood inside the tube.

Slots

The chiseling of the slots is the process in which the danger of cracking the base tube is greatest. Holes have already been drilled at either end of the slot. Next chisel out the strip between these holes, then enlarge the slot as needed with a chisel or knife (using a knife is safer, regarding splitting).

Frame

Once the postholes and slots are created, it is time to affix the posts that will support the rattles. I prefer to use quarter inch dowels for the vertical posts of the frame. One can also use bamboo sticks, sold in garden supply stores as tomato sticks, but these are usually a little crooked.

The post or posts to be held in the player's hand should extend through the base and up to the height of the tallest rattle in the frame. The other posts should each extend to slightly above the height of the node of each rattle

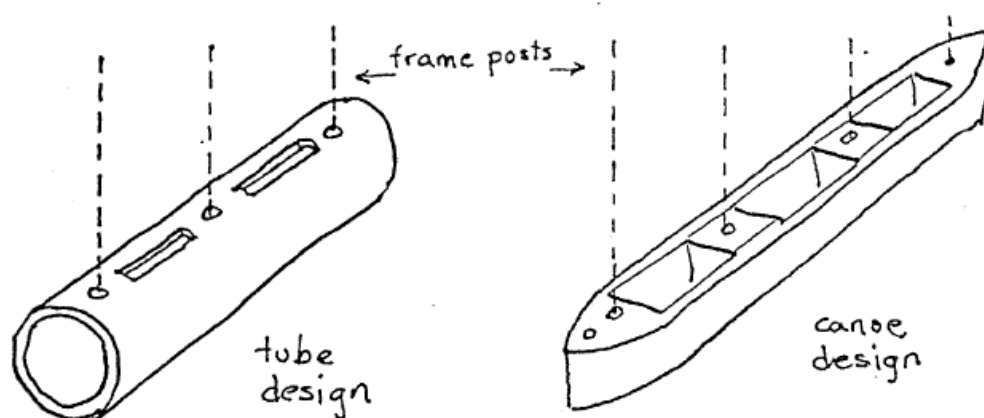

Figure 4. Designs for the base of the angklung.



Figure 5. Suspension hole and notched crosspiece.

in the frame, so that the crosspiece that passes through the suspension hole may be attached at the top of the post. Glue the posts into the base holes with epoxy.

Crosspieces must extend a bit more than the length between each post and the next. This allows enough overlap to the posts on each side. Crosspieces must be notched at the point from which the rattle is to hang (Figure 5). This notch can be triangular or square. With the rattle in place, attach the crosspiece to the posts on either side using thin string and glue.

Place the crosspiece at a height that enables the rattle to swing above the base with its feet in the slot. The rattles in the frame go from largest (on the side the player will hold) to smallest. They “face” out, away from the player—that is, the cut side of the rattle faces away from the person holding it.

Suspension Hole

The suspension hole allows the rattle to be placed into the frame of the angklung. To create the suspension hole, start by finding the point on the tongue that allows the greatest resonances when you hold the rattle at that point and strike it. It is usually a little above the middle of the tongue, but may even be below that point.

After you have found it, mark this point on the outside of the tongue and drill through using a ¼ inch drill bit from the outside to avoid chipping the outer skin of the bamboo.

The size and shape of the hole will depend on the type of crosspiece in the frame from which it will hang.

MAINTENANCE AND REPAIR

Bamboo is an organic material. Changes in humidity, particular too much dryness, are likely to make it crack. Avoid dry, overheated indoor storage. I don’t think actual temperature is a problem, but sudden temperature changes are probably bad.

A split rattle may sometimes be revived. In the case of cracks along the tongue (the most common place), glue the crack back together with epoxy and hold it in place with masking tape. In an emergency the tape alone will often do. Cracks that appear along the tube extending down from the lip may also be repaired with epoxy if they haven’t extended too far down. Once the bamboo opens up, you should just throw it out.

Because of the fragile nature of the organic material, it may be worthwhile for the angklung maker to experiment with various synthetics, either for the base or for the individual rattles as well. I have yet to try my hand at PVC or ABS or the various plastic-impregnated organic fiber materials, but they all present interesting possibilities. ▀

FESTIVAL



“Homecoming,” the theme of the International Gamelan Festival in August of 2018, was an apt description, as over a thousand participants from many nations and multiple Indonesian regions gathered in Solo for eight days of concerts, symposia, films, art and book exhibits, workshops, tours, and opportunities to interact for scholars, musicians, composers, and “gamelan lovers.” This list of performers, provided by the organizers, is just the beginning of the necessary documentation. The Festival opened with 73 gamelan groups (the years of Indonesia’s independence) playing simultaneously on the main street of Surakarta, followed by a week packed with spectacular events, headed by cultural luminaries like composer Rahayu Supanggani and film maker Garin Nugroho. A hard-working committee kept everyone fed during a celebration of gamelan both unprecedented and unforgettable.

7MM, Suwandi Widiyanto (Surabaya)	Paguyuban Rasa Amor Sukoharjo (Sukoharjo)
Ananda Sukarlan (Jakarta)	Paula Matthusen (USA)
Angklung Ragam Laras, Endah Irawan (Bandung)	Peni Candrarini (Solo)
Bambang Sukmo Pribadi (Surabaya)	Pura Mangkunegaran (Solo)
Blambangan Art School Rogojampi (Banyuwangi)	Pura Paku Alaman (Yogyakarta)
Carimakan, Mike Burns (Australia)	Raditya Art Community (Solo)
D’Esselon (Jakarta)	Ronald Kuivila (USA)
Dapur Kreatif Planet Harmonik, AL Suwardi (Solo)	Salukat, Dewa Alit (Denpasar)
Dedek Gamelan Orchestra (Solo)	Sambasunda (Bandung)
Dinamika Swara (Solo)	Sanggar Kesenian Tradisional Maraseneng (Kebumen)
Dwi Priyo Sumarto (Solo)	Sanggar Kirana (Malaysia)
Ensemble Kyai Fatahillah (Bandung)	Sanggar Manik Galih Colorado (USA)
Gema Swaratyagita dan Laring Project (Jakarta)	Sanggar Moreska (Flores)
Ghost Gamelan, Gondrong Gunarto (Solo)	Sanggar Seni Budaya Kikana Rahman Art Production (Sampang)
Githunk Swara, Githunk Sugiyanto (Semarang)	Sanggar Seni Iromo Turonggo (Magelang)
Irish Gamelan Orchestra (Ireland)	Sanggar Seni Jaranan Kudha Manggala (Tulungagung)
ISBI Bandung	Sari Raras (USA)
ISI Surakarta	Sean Hayward (USA)
Kanca Panglima Group, Lili Suparli (Bandung)	Sekoho Semara Pegulingan Gunung Jati, Puri Peliatan Teges (Bali)
Kanda Buwana (England) with Pangreksa Budi (Cirebon)	SingaMurti (Singapura)
Karawitan Prasanmitr, Srinakharinwirot University (Thailand)	Sinjang Community, Mutiara Dewi (Solo)
Kasultanan Yogyakarta (Yogyakarta)	Siswa Sukra (England)
Kasultanan Banjar (South Borneo)	Southbank Gamelan Players (England)
Kasultanan Kanoman Cirebon (Cirebon)	Sunardi (Yogyakarta)
Kasusunan Surakarta (Solo)	Surya Kencana (Hungary)
Komunitas JeDe (Medan)	Talago Buni (West Sumatera)
Kuaetnika, Djaduk Ferianto (Yogyakarta)	Unesa, Joko Porong (Surabaya)
Lambang Sari (Japan)	University Teknologi MARA Faculty of Music Gamelan Club (Malaysia)
Lembaga Incling Krumpyung (Kulonprogo)	Wahyu Thooyib Pambayun (Solo)
Lupi Anderiani (South Borneo)	Wendo Setiyono (Purbalingga)
M Hario Efenur (Padang)	Wesleyan Gamelan Ensemble (USA)
Malire, Dedy Satya Hadianda (Bandung)	Widosari (Holland)
Melathi Suryodarma (Solo)	Y. Subowo (Yogyakarta)
National Concert Hall Gamelan of Ireland (Ireland)	
Omah Cangkem, Pardiman Djoyonegoro (Yogyakarta)	

ESSAY

Gamelan: a cross-cultural, creative, community context for music-making.

by Jody Diamond (2000)

Thoughts on gamelan in education.

Gamelan: a set of melodic percussion instruments, originating in the Indonesian islands of Java and Bali. This multi-timbral ensemble represents one of the most beautiful, complex and highly developed classical orchestral traditions in the world. Gamelan is used in social and religious contexts, and in the most prominent arts institutions and performance venues in Indonesia. The instruments themselves display a pinnacle of craftsmanship, particularly in bronze. The music theory is fascinating and multi-layered, as it is intertwined with the cultural meanings inherent in the theater and language traditions of Java and Bali, particularly the multi-hour performance of shadow puppet theater.

a cross-cultural: In bringing a gamelan into a school, we establish a visual and sonic environment that by its very nature—the decoration, the shapes of the gongs, the positions of the players together on the floor with the instruments—begins immediately to teach about the cultural milieu of the land of its origin. The incredible richness of the music and associated arts of dance, theater and puppet theater can then be learned on this set of instruments. This gives students a direct experience of the art forms of another culture, and personal insight into the world view contained in those arts and the instruments on which they are expressed, whether a gong or a shadow puppet.

creative: The music flexibility of the gamelan, the ingenious structure of its instrumentation, and the unique beauty of its sounds all contribute to making the gamelan an ideal and fertile environment for creative exploration. The foreign student's inexperience with the gamelan actually

becomes a distinct advantage, as preconceptions both musical and personal are set aside in the process of entering a completely new musical environment. Composers find in the gamelan an orchestra that they can freely experiment with; musicians find new and unanticipated uses of their musical skills.

community: Happily, those with little previous musical experience find that the gamelan presents an opportunity to discover one's innate but previously undeveloped musicality. The many instruments of the gamelan differ in their musical and technical complexity. This allows the experienced player to be challenged and the beginning player to be useful; all players find themselves equally valued and essential. This social aspect of gamelan—a place for everyone—is quite attractive in an educational institution that wants to foster a sense of community and positive interaction among its members.

context: The gamelan creates a world of its own, a world into which a group of people may enter, discover, learn, create and perform together. The gamelan also serves as a node of connection to other areas of study: music, theater, acoustics, composition, language arts, area studies, humanities, and more.

for music making: Undeniably, the gamelan is an orchestra, an ensemble that is Indonesia's gift to the music-making world. All manners of sound that emanate from these tools may be experienced as music. All manner of music that may be conceived of might be expressed on these instruments in some way. When we place ourselves in the artistic environment of the gamelan room, we are at the center of an adventure that is just beginning. ▀

Jody Diamond (b. 1953) began to study gamelan at California Institute of the Arts in 1970; her first teacher was Pak Cokro (KPH Notoprojo). She has taught gamelan and Indonesian studies at many schools and universities, researched Indonesian composers and contemporary music for gamelan, and worked for many years with Lou Harrison. She founded the American Gamelan Institute in 1981, and the journal Balungan in 1984. Her first composition for Javanese gamelan was made on a Casio music calculator in Bora-Bora, French Polynesia.

This essay is from www.gamelan.org/jodydiamond/writing

SCORE

Prelude: Anyone Can Play

by Jody Diamond

Prelude: Anyone Can Play (1987) is a piece that contrasts chaos and order. It satisfies the audience's curiosity about the gamelan instruments before the concert begins, and can sometimes help to dispel the idea that the musicians are just "banging away up there." A performance of *Anyone Can Play* contrasts unstructured playing (audience improvisation) with highly organized playing (gamelan piece).

The score consists of two sections: instructions for the musicians, and a page of instructions to be given to members of the audience.

Musician's Instructions

Reproduce the audience page the same number of times as the number of musicians. As the audience enters, or after they are seated, hand each page discreetly to one member of the audience. The instruction page may be distributed by the musicians or by someone else.

At the start of the concert (indicated by dimming lights, or something similar) the musicians remain backstage, or alternatively, seated in the audience. The audience members will come up one by one and begin to play. Wait until all the audience members have come onto the stage, and allow them some time to play together, about 5 - 10 minutes, or however long it seems interesting. Sometimes you have to be patient.

After the audience "players" have had a chance to explore the instruments, the musicians come up to the stage one by one, going to the instruments they will play in the first piece. If there is an audience member playing there, the musician says "thank you" and takes the mallet from the audience member. This should be done quietly; the other audience members may still be playing. The musician does not yet play, but waits in place.

When all of the audience members have been replaced by the gamelan players, the gamelan begins a piece. There should be as short a pause as possible between the playing of the last audience member and the start of the gamelan piece.

The piece performed after the musicians are in place might be the first of the program, or another piece selected that will sound different from the explorations of the audience. It will ideally be complex, with many layers of density and embellishment. For example, the Mills College Gamelan has performed a Javanese *lancaran*, beginning in *Irama II*, with simultaneous *imbal* on *bonang*, *saron*, *demung* and *peking*. A more standard Javanese treatment would also be appropriate, such as a *ladrang* in *Irama III*. Any piece may be chosen that provides a marked contrast to the unstructured improvisation of the audience.

Prelude: Anyone Can Play



Jody Diamond

1987

AUDIENCE INSTRUCTIONS

You are invited to participate in the first piece on the concert. Please follow the instructions below.

- When the house lights dim (or everything is ready), walk up to the stage or area where the instruments are; do not take this page with you.
- Remove your shoes; leave them neatly on the floor in front of the stage.
- Go into the gamelan and find an instrument that looks interesting to you.
- Using the mallet that you find on that instrument, *carefully* explore the sounds of the instrument. (Drums are played with hands only.)
- Listen to the sounds you make. You may combine your sounds with the others around you, or play just for yourself.
- Continue to play until a player comes to take your place. When the player says "Thank you," relinquish your mallet. This will happen at one instrument at a time; continue playing until someone comes to play *your* instrument.
- Leave the stage quietly.
- Put your shoes on and return to your seat.
- Enjoy the rest of the concert.

Thank you for participating in *Anyone Can Play*.

(If you decide you would rather not play, please give this page to someone else.)

SCORE

Allahuakbar, and an invitation

by Sutanto Mendut (1989)

9. ALLAHUAKBAR

8. TAK TAK GENDENDANG DET GERRR
 7. KLING KLING KLING KLING KLING KLING
 6. NING NING NONG NONG NING NING GERRR
 5. NING NING NONG NONG NING NING GERRR
 4. TAK TAK GENDENDANG GENDENDANG
 3. TING TONG NING NANG NONG

8. KLING KLING KLING KLING KLING KLING
 7. TUNG TAK TUNG TAK BEM BEM BEM
 6. NING NING NONG NONG NING NING GERRR
 5. NING NING NONG NONG NING NING GERRR
 4. TAK TAK GENDENDANG DET
 3. TUNG TAK TUNG TAK

9. ALLAHUAKBAR

8. NING NONG NING NONG NING NONG NONG
 7. NING NANG NING GERRR NING NANG NING
 6. NING NING NONG NONG NING NING GERRR
 5. NING NING NONG NONG NING NING GERRR
 4. TAK TAK GENDENDANG GENDENDANG
 3. TUNG TAK TUNG TAK

9. ALLAHUAKBAR

8. NING NONG NING NONG NING NONG NONG
 7. TING TONG TING TONG TING TONG TONG
 6. NING NING NONG NONG NING NING GERRR
 5. NING NING NONG NONG NING NING GERRR
 4. GENDENDANG DET GENDENDANG DET GERRR
 3. TING TONG NING NANG NONG

9. ALLAHUAKBAR

2. BEM BEM BEM BEM
 1. ALLAHUAKBAR

2. BEM BEM BEM BEM
 1. ALLAHUAKBAR

2. BEM BEM BEM BEM
 1. ALLAHUAKBAR

2. BEM BEM BEM BEM
 1. ALLAHUAKBAR

BAGI JODY DIAMOND
 DAN LARRY POLANSKY

Sutanto, a composer and arts activist, lives in Central Java near Candi Mendut. Allahuakbar was composed in 1989 for Jody Diamond and Larry Polansky, who were researching composers and contemporary music in Indonesia. Sutanto invited others to create performance instructions for this piece. These are some of the contributions.

BENJAMIN BORETZ

Add these sentences to the score, one above and one below:

Respond to everything.

Don't say any of the words.

PHILIP CORNER

[email] Seems-to-me that the score is compleet azziz. Comprehensibl. Details of sequens there, etc. Whut-to-be add—only particulars as for any realization. by the performers: How many? Tempo? Expression? Degree-of-coordination? All-that not-necessary to compose befor. Ovcours percussion---but add noises. I also thought Voices. *Never the less sinseyouask here iz "my 2cents" —*

A OMNITHEOLOGOPHILOSOPHICULTSHURTEKNIQUE
ADDITIONAL TO PAK SUTANTO (hey! greetings) 'S
COMPOSITION ALLAHUAKBAR

At all appropriat occurence of the Allah-praise word—which to-be spoke—or shout—or whisper—or sung: Substitute or Add other deepmeaning phrases.....like; Hallelujah! Mio Dio! Shma Yisroel! Magnificat! Eureka! Amen! Yeah Man! Brahma! Dayenu! Muntu! Hare Krishna! Tao! Blessed! Ave Maria! Ex Nihilo! Beate! Peace! Uhuru! Love! Elohim! Jesus Christ! Holy Holy! Adonai! Inspiration! Legba! Jahveh! Jupiter! Aphrodite! Erzulli! Ahura Mazda! Justice! Life and Liberty! Gaia! Satori! Truth! Yoga! Omnisanti! Vox Popoli! Deus ex Machina! World Soul! Priapus! Bacchus! Mercy Mercy! Santangelo! Santa Claus! Revelation! Hurrah!

You get the idea.

Allthe best. and Love (add that) Ph. ▶

JODY DIAMOND

Talk

This is for any number of participants, each with a score. Each person chooses one side of the score to read aloud.

All begin together with line 1. After line 1, each person silently waits one full second—counted individually, not as a group—before reading line 2. After reading line 2, each person waits two seconds before reading line 3.

Continue in this manner, with each person waiting after each line the number of seconds matching the number of the line, with the following exception:

Read line 9 nine times, waiting nine seconds after each time. There will be a considerable difference in the way each person has counted the time. The piece ends when each person has finished performing line 9.

This realization may be varied as desired by the performers. The audience may be included.

(Counting concept after *Time Piece* by David Mahler.)

Sing

Assign a pitch to each vowel. Sing or play through every line. Pitches and procedure are up to the players. ▶

SKIP LAPLANTE

Set up

- 20 performers consisting of 16 vocalists and 4 instrumentalists.
- Performance space a large square with 4 vocalists on each side of the square at the outside edge.
- Drawing imaginary lines from corner to corner of the rectangle creates 4 triangular shaped spaces with the point of each triangle in the center of the square.
- At the very center of the square is a large drum. A mix of percussion instruments are scattered over each of the triangles, in 4 lines parallel to the outside edge. Each instrumentalist plays only the instruments in his or her triangle and works only with the vocalists on the outside edge of that triangle.

Process

The vocalists work as teams of 4, each team working thru their sequence of words. There is an overall beat that once established by the first team continues thru out.

Starting with the outside set of words, one vocalist claps the beat while another speaks the words. Rests and more rapid text movement (i.e. eighth notes in a quarter note texture) are at the discretion of the performers.

The whole phrase is then repeated by the 4 vocalists, perhaps receiving more extreme treatments until such time as the instrumentalist chooses to begin playing.

The instrumentalist's first note is the cue for the vocalists to stop. The instrumentalist then performs the phrase using a mix of instruments to reproduce the text. All text Gir, Grr etc should be performed on instruments that buzz for a while after the sound is initiated. The phrase is played once. The process then repeats for the text one level closer to the center of the score. The instrumentalist moves from the line of instruments furthest from the center to another line of instruments nearer the center.

Each of the 4 groups may start whenever they choose, and once started, complete their journey thru the text without regard to the progress of the other groups other than to maintain a common pulse.

As an instrumentalist completes his or her rendition of the 4th line of text, he or she moves to the drum at the center and plays bem bem etc as a steady pulse on the drum which continues until all the instrumentalists have joined in at the drum.

Before each performance, each group of 5 determines how they will perform the final line without consulting with or informing the other groups of their decision. At a cue (probably from one of the drummers but any cue acceptable to all is fine) each group performs their version of the final line in unison, or rather beginning at the same time. ▶



DAVID MAHLER

Here are five short pieces in which the score, along with four performers and a leader, is a player.

Each performer and the leader holds a copy of the score throughout. In pieces II and IV, each performer chooses one side of the score-square from which to read or chant. Choices of sides of the score should be agreed upon beforehand, and all four score sides should be in play.

A brief improvised instrumental drone or a repeated pattern, played by any number of additional performers, may precede any of these five realizations of *Allahuakbar*. No instruments should be played following number V.

For each piece, four performers, equidistant from each other, form a diamond, the size of which is proportional and appropriate to the size and location of the audience. Each performer faces the center of the diamond. A fifth person, the leader, stands in the center of the diamond.

I

When the leader waves her score, the performers speak in unison the text of lines 1 and 2 from their scores. The performers then turn, in place, to their left. The leader waves her score and the performers repeat speaking 1 and 2. Three more iterations of left turns, leader score-waves, and speaking take place. By the last recitation, speakers are facing each other again.

II

Each performer chooses one of the four sides of the score. The leader holds the score high above her head with two hands, walking in a clockwise circle within the diamond.

Each performer, when the leader passes in front of them, reads line 3. The next time the leader passes in front of them, performers read line 4, and so on, until each performer has read all the lines, 3 through 9.

The leader varies the speed of her walking at her discretion. Tempos range from very slow to very fast. There is no attempt to coordinate readers. All maintain their independence.

At any time, the leader may reverse the direction of her walking. When she passes in front of a performer, the performer continues advancing their reading, that is, if they just read line 4, they now read line 5. The piece is finished when all four players have read all of the lines.

III

Leader and performers intone line 1 and 2 in rhythmic unison, each person selecting their own pitch.

Immediately after this, performers raise their hands requesting an assignment from the leader. Hands remain raised until leader acknowledges a performer by standing directly in front of them.

The leader will assign an orientation by turning her score to any side of the square. She will then assign a line (3 to 9) for the performer to intone by holding up 3, 4, or 5 fingers, and, for numbers higher than 5, by holding up 5 followed by 1, 2, 3, or 4 fingers.

A performer, when assigned an orientation and a number, intones that line any number of times. When finished with that line, they raise their hand for another assignment.

The process continues until either no performer raises a hand, or the leader no longer recognizes any raised hands.

IV

Each performer intones their part, lines 1 through 9, changing pitch or not for each new number. Leader signals when to begin, and the chanting starts, at a fairly fast tempo.

Leader holds the score in one hand, with which she designates dynamics. When the score is held highest, dynamics are loudest. When the score is held lowest, dynamics are quietest. A continuum between high and low allows for crescendos and diminuendos.

Repeat a total of four times. On each of the four iterations, performers begin together. An earnest attempt to chant in rhythmic, as well as dynamic unison is encouraged, even though the results may be ragged.

V

By holding an edge of her score and shaking it, the leader instigates four separate unison score flutters, in tempos of 1) very fast; 2) medium fast; 3) medium slow; 4) very slow.

The four performers join the leader, each performer holding an edge of their score and shaking it, making the score flutter.

Each group flutter of all five scores should last a minimum of seven seconds, and there should be about a five second pause before the next one. ▀

MONOGRAPH

Formal Aspects of Performance Practice In Central Javanese Gamelan Music

by Roger Vetter

Preface

Certain aspects of Central Javanese gamelan performance practice have fascinated me from my earliest encounters with this music tradition in 1973, when I joined the University of Hawaii gamelan ensemble under the direction of Pak Hardja Susilo. In particular, how was it that a neatly organized block of ciphers on a sheet of paper titled something like *Ladrang Pangkur* could reside at the core of a realization of itself that consumed twelve or more minutes of time with layer-upon-layer of melodic and rhythmic gestures produced by over a dozen musicians who were not following detailed notational instructions? This question, and the drive to provide myself with answers to it, has stuck with me over my forty-five years of involvement with Javanese gamelan music. As a music theory graduate student, my 1977 M.A. thesis, reproduced here in its nearly-original form¹, was a first attempt at putting into words my evolving understanding of Javanese gamelan performance practice. I would continue over the years to

How do we comprehend a new musical system while we are participating in it? This article shows how Vetter, using the intellectual and analytical tools of his own background, attempted to make sense of the complex sound world that he had entered with both passion and curiosity. His writing reveals as much about the adventure of the mind as about the music itself.

Vetter used observations from his own experience, along with printed and recorded material available at the time, to postulate categories and rules of engagement guiding the gamelan music and musicians he encountered in Central Java. I am pleased to be able to share Vetter's insights and graphic representations of time and form with others who have encountered this rich musical tradition. The entire thesis in its original form, including parts not included here, is online (under current edition or with back issues) at www.gamelan.org/balungan.

—jody diamond

Roger Vetter is an ethnomusicologist specializing in the gamelan of Central Java, with an extensive knowledge of the court gamelan of Yogyakarta. This article is from his master's thesis, written at the University of Hawaii in 1977 when he was a musicology student who had been playing Javanese gamelan for only five years. He was trying to understand, and find a way to explain to others, the "formal forms and processes" of this tradition.

incorporate my ideas about form that were first developed in this thesis in other scholarly efforts: my 1981 article "Flexibility in the Performance Practice of Central Javanese Music" (*Ethnomusicology* 25/2: 199-214), in my dissertation "Music for the 'Lap of the World': Gamelan Performers, Performance, and Repertoire in the Kraton Yogyakarta" (University of Wisconsin-Madison, 1986); and in "Flexing the Frame in Javanese Gamelan Music: Playfulness in a Performance of *Ladrang Pangkur*," a chapter co-authored with Andy Sutton that appeared in *Analytical Studies in World Music* (Tenzer, 2006).

My primary goals in researching and writing this thesis back in 1977 were to define some fundamental form-related aspects of the Javanese gamelan tradition and to examine how they interact during performance to create large-scale formal relationships—what I call the formal process. I used as my data for this project published books of gamelan notation and commercially-available audio recordings of performances by professional Javanese gamelan groups, the majority of these recordings produced by the Indonesian national recording company Lokananta. These resources provided me with two very different representations of gamelan pieces: the notation collections presented lean encapsulations of the melodic framework (balungan) and phrase structure (colotomic) of pieces; the recordings presented me with case studies of unique realizations of those notational frames and examples of how performers flex or play with their apparent rigidity in the course of performance. I subjected both of these resources to analysis of one sort or another to suggest generalizations about 1) Javanese melodic/balungan organizational sensibilities, 2) the options musicians have in the course of a performance in regard to the repeating, the temporal flexing, and the editing of melodic/structural material, and 3) the sequential joining of pieces into medleys. The result is not a complete explication of Javanese gamelan performance practice, but a foundational overview of the formal processes at work in the performance practice of this tradition. Although compositional innovations have been introduced into the world of gamelan performance since the writing of my thesis some forty-two years ago, I feel confident that the observations and generalizations about Central Javanese gamelan performance practice set forth herein are still pertinent in contemporary practice.

—Roger Vetter, Grinnell College, 2019

THE GAMELAN TRADITION

The Gamelan Orchestra and Its Music Tradition

Throughout Mainland and Insular Southeast Asia there are numerous orchestras—such as the *pi phat* of Thailand, the *saing waing ah-pwe* of Burma, the *pin peat* of Cambodia, the *kulintang* of the Philippines, and the gamelan of Malaysia and Indonesia—which are comprised in part or predominantly of percussion instruments made of metal (bronze, brass, or iron). The construction, composition, style of playing, pitch and formal organization, and repertoire of these orchestras and their traditions differ not only from one country to the next, but often between regions within the same country. Within Indonesia there are numerous differences between the gamelan orchestras and music traditions found on the island of Bali and those on the island of Java. Indeed, on Java alone there are a number of distinct gamelan traditions that make it difficult to generalize about a single tradition of even this one island. Thus, when using the word “gamelan” it becomes necessary to clearly specify which “gamelan” tradition is being referred to. Here “gamelan” will refer to the Central Javanese orchestra and its music tradition.

There are thousands of gamelan on the island of Java alone, and the instruments of one gamelan are not interchangeable with the instruments of another gamelan (Kunst, 1973:546–571). The casings of the instruments of any one gamelan are carved and painted uniquely, and the chances of finding two gamelan tuned exactly alike are quite slim. Gamelan are housed in palaces, radio stations, wealthy merchants' houses, business offices, etc. Musicians meet at these places to rehearse and perform rather than owning their own instruments. Each gamelan is unique, and many are given their own name, e.g. *Kyai Guntur Madu* (“The Venerable Torrent of Honey”), *Kyai Udang Asih* (“Venerable Shower of Love”), and so forth, to express the emotional feeling (*rasa*) created by its sound.

Flexibility in the Gamelan Tradition

Gamelan music was, until recently, entirely orally transmitted. Today the use of notation as a means of preservation and transmission is becoming more accepted, although a standard system of notation is lacking (Kunst, 1973:346–355; Becker, 1972:30–60). Gamelan music has built into it a high degree of flexibility, and to appreciate this tradition and understand the limitations of even a detailed notational system one must be aware of its basic nature.

The pitch organization of gamelan music offers a good example of this flexibility. There are two tuning systems, called *laras*, used in gamelan music: *slendro*, which is pentatonic with roughly equidistant-intervals, and *pelog*, which is heptatonic with a variety of interval sizes. The exact pitch and intervallic relationships that exist in these two tuning systems differ from one gamelan to the next. Thus, the instruments tuned to *slendro* in one gamelan will probably not match the *slendro* pitches of another

gamelan, and if measurements of the interval sizes between corresponding steps of the two *slendro* tunings were taken, these would also likely differ. The same applies to *pelog* tuning system.

The process by which gamelan pieces are realized—the tradition's performance practice—is another excellent example of flexibility. On a micro-level, most of the individual instrumental parts can be realized by knowing a few basic details. If the melody, tuning system, and mode (called *pathet*) of a piece are known, a competent musician should be able to realize a traditionally acceptable part on any instrument he or she knows (and most experienced gamelan musicians know several instruments well enough to do this). One competent musician's realization of a particular piece on a particular instrument may not be the same as another's, yet both may be acceptable.

On a macro-level, the overall formal result of any piece can vary from one performance to the next. Performance practice allows for a wide range of acceptable realizations, depending on how many times a piece or a section of a piece is repeated, what tempo or tempi it is performed at, whether or not certain variable sections of a piece are performed, and whether or not another piece is inserted into the original piece.

Musical Functions of Instruments in the Gamelan

Each instrument type carries out a singular musical role in gamelan performance practice. An instrument can be thought of as fulfilling one of five basic musical functions: melodic, structural punctuation, melodic abstraction, melodic elaboration, or tempo control. The two groups of instruments functioning as melodic (or “*balungan*” instruments) and as structural punctuation instruments (or “*colotomic*” instruments) will be of the greatest importance to the discussion that follows.

Balungan Instruments

The melodic instruments of the gamelan are the *saron barung*, *saron demung*, and *slenthem*. They are, for the most part, single-octave instruments that play the *balungan* (lit. skeleton) of the piece. “*Balungan*” has been variously described as a “*saron part*,” “*nuclear theme*,” “*fixed melody*,” “*cantus firmus*,” etc. None of these terms, for one reason or another, is quite satisfactory. Sutton says: “... the concept ‘*balungan*’ may be defined as a single-octave melodic outline, almost always realized on one or more of the *balungan* instruments” (Sutton, 1975:31). This is probably the safest definition and the one to be used here. The *balungan* of most pieces are successions of pitches in a steady, even pulse. Rhythmic variety in a *balungan*, when present, is created either by sustaining a pitch through one or more *balungan*-pulses or by adding tones between two consecutive *balungan*-pulses in duple (sometimes quadruple) subdivision. Hereafter, the term “*balungan*” will refer to single-octave melodic outlines as they exist in the gamelan repertoire. The term “*balungan-pulse*” will always refer to an

underlying even pulse, void of any rhythmic variety.

An important characteristic of the balungan-pulse is the grouping of four pulses to form a unit called a *gatra*. Comparing a *gatra* to the Western concept of a musical bar or measure is counterproductive, mainly due to a difference in metric accent. In a measure of 4/4 meter the metric accent is understood to be (accents in bold) **1 2 3 4** (with the first beat stronger than the third) while in a *gatra* the metric accent would be: **1 2 3 4** (with the fourth beat stronger than the second). Although gamelan musicians do not add a dynamic accent on either accented pulse of a *gatra*, other musical actions, such as the activities of the accentuating, elaborating, and abstracting instruments, reinforce these pulses and create stress. For clarity here, the *gatra*, when notated, will be set off as a unit of four pulses separated by a space.

1 gatra 1 gatra
 balungan-pulse •••• ••••

Gamelan music is cyclic in nature, and begins and ends at the same point. Thus, the initial balungan-pulse of a piece is not the first pulse of the first *gatra* but the last pulse of the piece's introduction (called the *buka*). The balungan-pulse immediately following this initial pulse is the first pulse of the first *gatra*, as shown below.

end of buka first gatra
 balungan-pulse • ••••

Colotomic Instruments

In scholarly studies, the group of accentuating instruments as a whole is labeled the "colotomic instruments" (Kunst, 1973:296; Hood and Susilo, 1967:16; Susilo, 1967:9). These instruments punctuate the balungan-pulse in patterns of varying design that, here, will be called "colotomic patterns." These patterns are fundamentally important to the delineation of structure in gamelan music. The colotomic instruments can be considered as two groups differentiated by their details of construction, suspension, and sound envelope characteristics.

The first group of colotomic instruments is the vertically-suspended knobbed-gongs. These instruments are struck with thickly padded beaters to produce a soft attack and long decay of sound. The *gong ageng*, *siyem*, and *kempul* comprise this category. The *gong ageng* is the largest and lowest-pitched instrument in the gamelan and has a long decay of sound. There are only one or two *gong ageng* in each gamelan. Pitched in the octave above the *gong ageng* are the *siyem*, more formally called the *gong suwukan*. Gamelan usually have more *siyem* than *gong ageng*, the exact number varying from one gamelan to the next. *Kempul* are pitched in the octave above the *siyem* and are the smallest members of this group of colotomic instruments. Generally speaking, there is a *kempul* for nearly every pitch of both tuning systems, although there is no fixed number to be found in all gamelan.

Since the sound decay period of the *gong ageng* can last for several seconds, it is quite common to substitute the *siyem*, with their shorter decay period, in pieces with short *gong* phrases. When serving this function, both these instruments will be referred to as "gong." If the *siyem* is used in another capacity, it will be referred to as "siyem."

Horizontally-suspended knobbed gongs—the *kenong*, *kethuk*, *kempyang*, and *engkek-kemong*—constitute the second group of colotomic instruments. These instruments are struck with thinly padded, thus relatively harder, beaters, which produce a sharper attack and a shorter sound decay period than those of the horizontally-suspended colotomic instruments. The *kenong* are pitched two octaves above the *kempul*, and most gamelan have a *kenong* for nearly every pitch of both tuning systems. There is only one *kethuk* for each tuning system, their pitch falling in the octave above the *kempul*. The *kempyang* (used only in the *pelog* tuning system) and the *engkek-kemong* (used only in the *slendro* tuning system) are pairs of small gongs. Their roles in the delineation and classification of structures are of secondary importance and will not be discussed here.

Three terms that relate directly to the colotomic instruments are *gongan*, *kenongan*, and *wela*. The first two terms describe musical units set off by strokes of *gong* 5 and *kenong* respectively. A *gongan* is the musical unit that begins immediately after a stroke of *gong* and ends on the next stroke of *gong*. Likewise, a *kenongan* is the musical unit that begins immediately after a stroke of *kenong* and ends on the next stroke of *kenong*. The term *wela* identifies a structurally important point that does not coincide with a colotomic event.

THE FORMAL STRUCTURES OF GAMELAN MUSIC

Delineation of Formal Structures

Structure in gamelan music can be conceived of as the product of the interaction of two musical variables: 1) repeating musical patterns formed by the composite activities of the colotomic instruments, in this work labeled "colotomic patterns," and 2) the number of balungan-pulses in a colotomic pattern.

A colotomic pattern is more than a punctuating rhythmic cycle, since each event comprising it has particular characteristics of timbre and pitch. When combined with the tone and octave placement of each colotomic event, a colotomic pattern becomes a complex, multi-dimensional component of the entire gamelan texture. Figure 1 gives the octave placement and tones of each of the colotomic instruments in one typical *slendro* gamelan (*Kyai Gundrung*, a Yogyanese gamelan at the University of Hawaii). The octave placement of the colotomic instruments in the *pelog* tuning system is similar. When interpreting figures and transcriptions in this work, note that the symbol used to label a colotomic event communicates the dimensions of timbre and pitch as well as the rhythmic placement of that event.

slendro pitches	symbol	octave					
		low	1	2	3	4	high
kenong	N	xxxxx	xxxxx	xxxxx	xxxxx	xxxxx	
kethuk	t					x	
kempul	P			xxx	xx		
siyem	S		x	xx			
gong ageng	G	x	x				

Figure 1. Octave Placement and Pitches of the Colotomic Instruments.

Groupings of Formal Structures

Most gamelan pieces fit into one of three groups, differentiated from one another by the structure of their colotomic patterns:

- 1) structures with a two-kenongan-per-gongan colotomic pattern;
- 2) structures with a four-kenongan-per-gongan colotomic pattern; or
- 3) structures with gongan of variable length.

The colotomic patterns of the first two groups are complete gongan differentiated from one another by the number of kenongan each contains. Within a piece with one of these structures the gong ageng or siyem will be sounded at the end of each repetition of its colotomic pattern. This type of structure is labeled "strict" by Susilo (1967:8) based upon this regularity of gong punctuation. In each of these two groups there are structures that use kempul in their colotomic patterns and those that do not. Various colotomic patterns for the first two structural groups are shown in the following figures.

The design of the colotomic pattern for the group of two-kenongan-per-gongan structures that use kempul is shown in Figure 2. It is best expressed as a circle due to the cyclic nature of the music. This cyclic colotomic pattern, as well as those for the other strict group of structures discussed below, can be conceived of as the composite result of several sub-cycles of punctuation activity each of which is associated with one type of colotomic instrument. Figure 3 diagrams the sub-cycles for this particular group of structures.

The design of the colotomic pattern for the group of two-kenongan-per-gongan-without-kempul structures is in Figure 4. Although not shown in this diagram, the kethuk plays a very important role in these structures. However, since the design of the kethuk subdivision varies within and between structures in this group, the details of kethuk punctuation will be presented later (see Two- and Four-Kenongan-without-Kempul Structures).

The colotomic pattern for the group of four-kenongan-per-gongan-with-kempul structures is presented in Figure 5, while that for the four-kenongan-per-gongan-without-kempul structures is found in Figure 6. There are several possible kethuk subdivisions of the gongan for the latter group (discussed later).

The colotomic pattern for the third group of structures, unlike those for the first two groups, does not

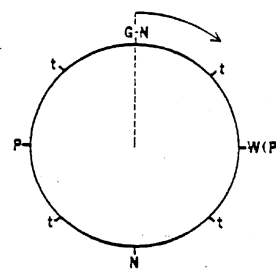

Figure 2. Colotomic Pattern for Two Kenongan-per-Gongan Structures, Using Kempul.

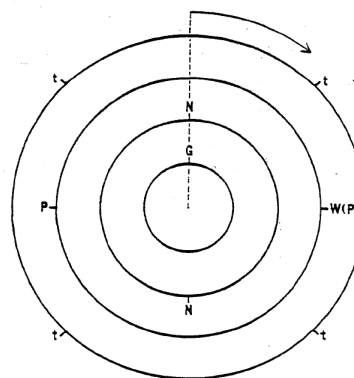

Figure 3. Individual Colotomic Instrument Subcycles for the Group of Two Kenongan-per-Gongan Structures, Using Kempul.

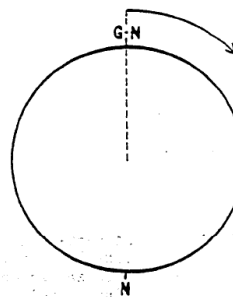

Figure 4. Colotomic Pattern for Two Kenongan-per-Gongan Structures, Not Using Kempul.

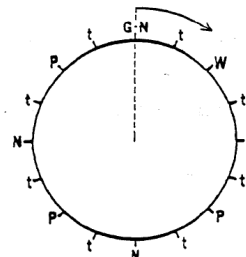

Figure 5. Colotomic Pattern for Four Kenongan-per-Gongan Structures, Using Kempul.

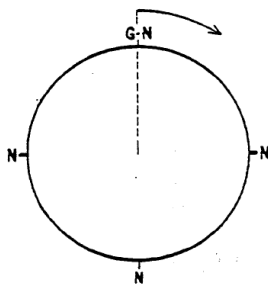

Figure 6. Colotomic Pattern for Four Kenongan-per-Gonggan Structures, Not Using Kempul.



Figure 7. Colotomic Module for the Group of Structures with Gonggan-s of Variable Length.

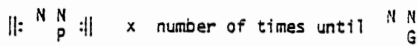

Figure 8. A Gonggan in the Free Structures

constitute a gonggan. This pattern, diagramed in Figure 7, is repeated a number of times before a gong (either a siyem or a gong ageng) is struck instead of a kempul at the end of the pattern, as shown in Figure 8. This modular construction allows for gonggan of variable length within a piece. Structures with this type of colotomic pattern are called “free” by Susilo (1967:8). Because of the modular nature of these structures, this pattern will be referred to as “colotomic module” (CM).

Descriptions of the Formal Structures

Several formal structures exist in the Javanese gamelan tradition, some of which are applied to numerous pieces in the repertoire, others to only one or a few pieces.

Two-Kenongan-per-Gonggan-with-Kempul Structures

Ketawang (Figures 10 and 11): sixteen balungan-pulses per gonggan grouped into two 8-balungan-pulse kenongan. The Solonese version of this structure has the kempul sound in the middle of the second kenongan only (Figure 10). In Yogya, the kempul is sounded in the middle of both kenongan (Figure 11).

Four-Kenongan-per-Gonggan-with-Kempul Structures

Lancaran (Figure 12): eight balungan-pulses per gonggan grouped into four 2-balungan-pulse kenongan.

Bubaran or *Bibaran* (Yogya) and *Lancaran Mlaku* (Solo) (Figure 13): sixteen balungan-pulses per gonggan grouped into four 4-balungan-pulse kenongan. In Solo this structure often uses the same drumming pattern as the *lancaran*

structure. In Yogya, the *bubaran* structure has its own specific drumming pattern and is considered a more autonomous structure.

Ladrang (Figure 14): thirty-two balungan-pulses per gonggan grouped into four 8-balungan-pulse kenongan

Two- and Four-Kenongan-per-Gonggan-without-Kempul Structures

The structures belonging to these two groups have two sections, the first called *merong* (Solo) or *dados* (Yogya) and the second *inggah* (Solo) or *ndawah* (Yogya). These sections differ in the number of kethuk strokes per kenongan and/or the number of balungan-pulses per kenongan and gonggan. The exact size and design of these structures can be discerned by three factors: 1) the number of kenongan per gonggan, 2) the number of kethuk strokes per kenongan, and 3) the position of the kethuk strokes within the kenongan.

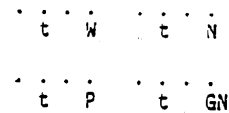

Figure 10. Solonese Ketawang Structure.

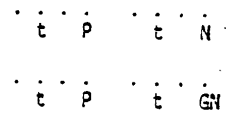

Figure 11. Yogyanese Ketawang Structure.

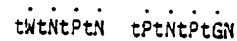

Figure 12. Lancaran Structure.

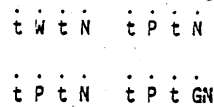

Figure 13. Bubaran or Lancaran Mlaku Structure.

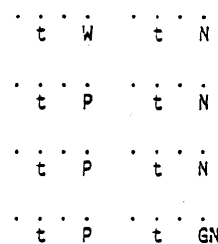

Figure 14. Ladrang Structure.

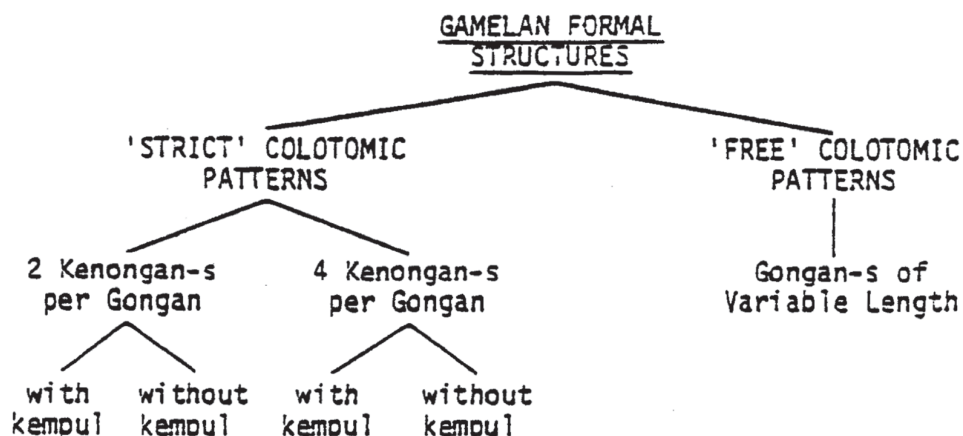

Figure 9. Groups of Gamelan Formal Structures

If a structure is labeled *ketawang gendhing* it has two kenongan in each gongan; if it is called simply *gendhing* it has four kenongan in each gongan. The number of kethuk strokes per kenongan in these structures will be either 2, 4, 8, or 16. Figure 15 plots out comparatively the subdivision of the kenongan for each of these options and reveals an underlying organizational symmetry of punctuation. Wela are recognized midway between strokes of the kethuk except where the kenong sounds. Generally, the larger the structure the more need there is for a greater number of kethuk strokes to serve as secondary structural markers to the more important, but less frequent, kenong strokes.

There is specific Solonese terminology for the frequency and position of kethuk strokes within the

kenongan of sections of these two- and four-kenongan-per-gongan-without kempul structures.

kethuk: the kethuk sounds in the middle of each gatra of the kenongan,

kethuk kerep: the kethuk sounds at the end of every other gatra starting with the first gatra of a kenongan (kerep means frequent),

kethuk arang: the kethuk sounds at the end of every fourth gatra starting with the second gatra of a kenongan.

There are nine different kenongan structures found in two- and four-kenongan-per-gongan-without-kempul structures. These are diagrammed in Figure 16 and grouped according to their number of balungan-pulses per kenongan.

Generally speaking, the merong section of these structures has half as many kethuk strokes per kenongan and a different position of kethuk strokes as its inggah section. An exception to this proportion of kethuk strokes in each section occurs when a piece in a strict structure using kempul, represented by the kenongan-type 1 (kethuk 2), is used as the inggah section. This is a common occurrence in *ketawang gendhing* and is also found in four-kenongan-per-gongan *gendhing*. Figure 17 lists the various *ketawang gendhing* and *gendhing* structures encountered in the written and audio resources consulted for this work.

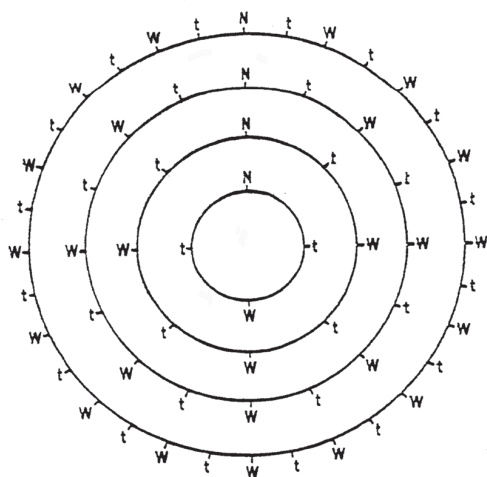

Figure 15. The Various Kethuk Subdivisions of the Kenongan in 'Strict' Structures Not Using Kempul.

Structures with Gongan of Variable Length

The colotomic module for these free structures can be repeated a number of times before a gong sounds at the end. Individual structures within this group are differentiated by the number of balungan-pulses per repetition of the colotomic module. The naming of the individual structures in this group is confusing due to differences in terminology between Yogya and Solo.

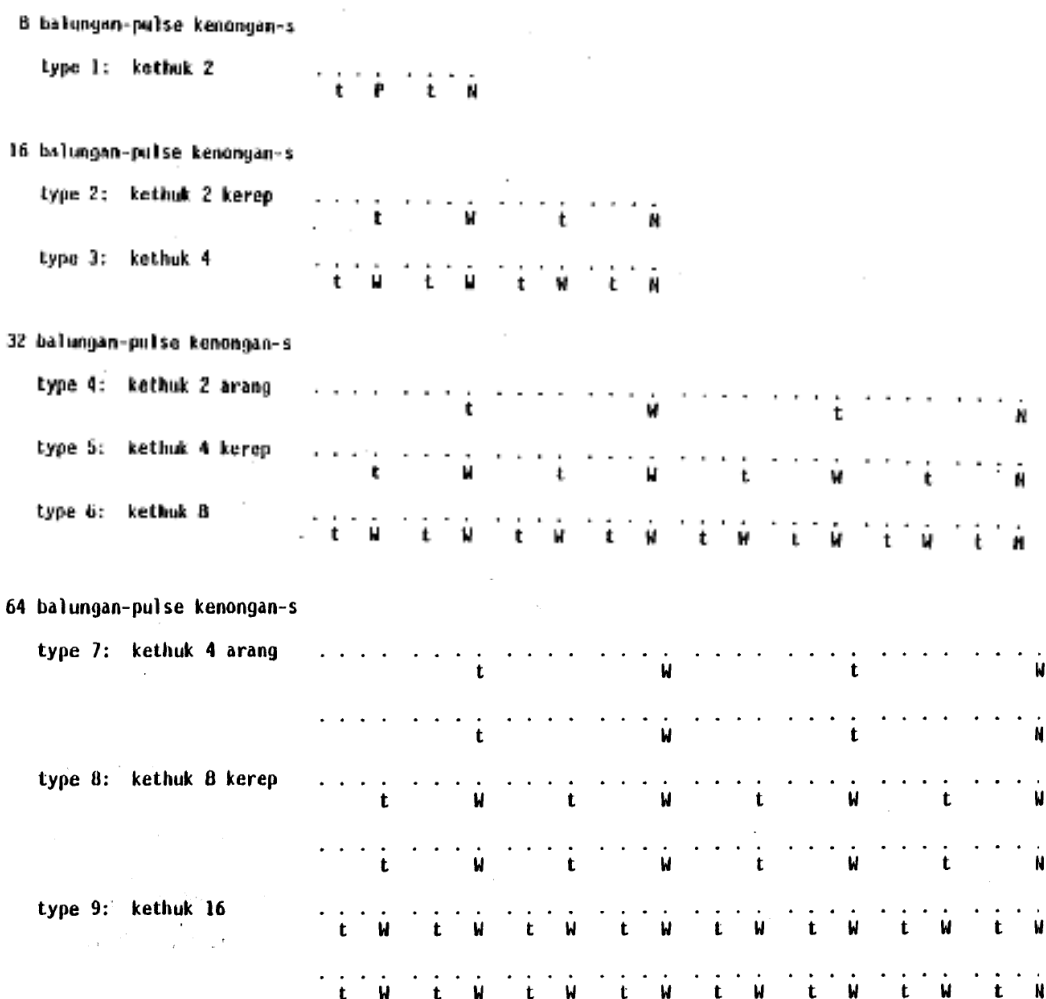
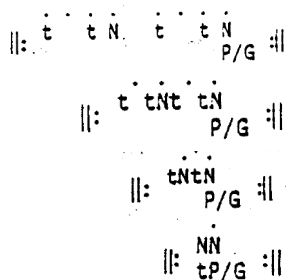

Figure 16. Nine kenongan types found in two- and four-kenongan-per-gongan structures not using kempul.

	merong section	# of bp per gongan	inggah section	# of bp per gongan or section	inggah section	# of bp per gongan
ketawang gendhing-s	kethuk 2 kerep	32	kethuk 2	32	kethuk 4	64
	kethuk 4 kerep	64	kethuk 2	32		
	kethuk 8 kerep	128	kethuk 16	128		
gendhing-s	kethuk 2 kerep	64	kethuk 4	64	kethuk 2	32
	kethuk 2 arang	128	kethuk 4	64	kethuk 2	32
	kethuk 4 kerep	128	kethuk 8	128	kethuk 2	32
	kethuk 4 arang	256	kethuk 8	128		
	kethuk 8 kerep	256	kethuk 16	256		

Figure 17. Two- and four-kenongan-per-gongan structures not using kempul.



From the top, Figures 18–21.

Ayak-ayak (Yogya): eight balungan-pulses per colotomic module (Figure 18). This structure does not exist in Solonese practice.

Srepegan (Yogya) and *Ayak-ayak* (Solo): four balungan pulses per colotomic module (Figure 19). This structure is also used for Solonese pieces labeled *bentuk kemuda*.

Sampak and *Playon* (Yogya) and *Slepegan* (Solo): two balungan pulses per colotomic module (Figure 20).

Sampak Gara-gara (Yogya) and *Sampak* (Solo): one balungan-pulse per colotomic module (Figure 21).

STRUCTURAL FLEXIBILITY

The formal structures as introduced in the previous section appear rigid and void of any temporal referent. In this section, the ways in which Javanese gamelan performance practice allows these abstract and rigid structures to be temporally flexed and structurally interrupted will be introduced.

Irama

In the gamelan tradition the relationships created between a musical unit and the units that divide it are fundamental to the delineation of several musical phenomena. The division of the gongan into kenongan (or colotomic modules) and balungan-pulses is essential to the identification of many structures. Thus far, the balungan-pulse has been the smallest unit of division discussed, functioning only on structural levels (those levels of the musical hierarchy involving units larger than the balungan-pulse, i.e., *gatra*, *kenongan*, *colotomic module*, and *gongan*.) This same pulse is subdivided by certain instruments that play at a higher rhythmic density. The fastest subdividing pulse of any given musical texture is called the “density referent” by Mantle Hood (1971:114). The density referent in gamelan music is of particular importance to the delineation of what is called “*irama*.” Irama, defined by Sutton (1975:50) as “... the rhythmic relationship between the balungan beat (pulse) and the parts that subdivide it,” can be expressed as a ratio of the number of density referents (DR) to one balungan-pulse (bp). The number of DR per bp is determined by the tempo of the bp, so irama is a function of the bp tempo. The number of DR per one bp can be 2, 4, 8, 16, or 32. These five rhythmic relationships are most commonly called irama *seseg* (or irama *lancar*), irama *tanggung* (or irama *siji/satu*), irama *dados* (or irama *loro/dua*), irama *wilet* (or irama *telu/*

irama	# of DR	to	bp
seseg	2	:	1
I	4	:	1
II	8	:	1
III	16	:	1
IV	32	:	1

Figure 22. Rhythmic Relationships of the Five Irama-s.

tiga), and irama *rangkep* (or irama *papat/empat*). Hereafter, the five irama will be referred to, respectively, as *seseg*, I, II, III, and IV (Figure 22). Theoretically, the rate or tempo of the DR (called *laya*) in all five irama is approximately the same, although in performance distinctions can be made between three tempi for each irama: slow (*tamban*), moderate (*sedheng*), and fast (*seseg*). The general effect on the tempo of the bp is one of doubling with each successive irama, i.e., the bp tempo in irama I is twice that of irama II because it has half as many DR.

A survey of metronome readings (MM) from sections of several recordings, summarized in Table 1, reveals the range of tempi for each irama encountered in actual performance practice. The average balungan-pulse tempo (bp-MM) and average density-referent tempo (DR-MM) are also given. Two tendencies are apparent: first, when going from a higher irama (one with fewer DR) to a lower irama (one with a great number of DR) the tempo of the bp will always be slower; and second, the rate of the DR can be the same, slightly faster, or slightly slower when going from one irama to another (notice that there seems to be a preference for the rate of the DR to be faster in irama I and IV than in the other irama).

The effect of irama on a structural level is a magnification of what happens on the bp level. This can be demonstrated by deriving performance times for one gongan of the 32-balungan-pulse *ladrang* structure in all five irama using the average balungan-pulse tempos (bp:MM) given in Table 1:

- irama *seseg*: 15 seconds
- irama I: 20 seconds
- irama II: 59 seconds
- irama III: 1 minute 59 seconds, and
- irama IV: 3 minutes 10 seconds.

irama	# of samples	range of bp-MM	average bp-MM	average DR-MM
seseg	6	116–144	128.3	256.6
I	9	80–104	95.1	380.4
II	15	27–44	32.7	261.6
III	8	14–17	16.1	257.6
IV	6	10–11	10.1	322.6

Table 1. Balungan-Pulse Tempo Survey

Regardless of whether the performance time for one gongan takes fifteen seconds or more than three minutes, it is still recognized as a *ladrang* structure as long as the criteria for this structure are met.

	ssg	irama-s			
		I	II	III	IV
STRICT STRUCTURES	ketawang	x	x	x	
	gending ket. merong	x	x		
	lancaran	x	x	x	
	inc. miaku and bubar	x	x	x	
	ladrang	x	x	x	x
	gending merong	x	x		
	inggah	x	x	x	x
	ayak-ayak	x	x	x	
	slepegan	x	x	x	
	sampak	x	x		
FREE STRUCTURES					

Table 2. Irama-s Possible for each Gamelan Structure.

Not all gamelan structures are realized in all iramas. While pieces in nearly every structure can be performed in iramas I and II, pieces in a much narrower range of structures can be performed in iramas seseg, III, and/or IV. Only some pieces in the ladrang structure can be performed in all five iramas. Table 2 lists the iramas possible for each structure as encountered in the research.

Irama Change

In the process of realizing a piece in performance it is common to change from one irama to another. Irama changes are generally made between adjacent irama and in either direction. There are two basic ways to change irama.

1) Slow down or speed up to a point where the instruments creating the DR must either double or cut in half their density. Sutton (1975:53) graphs this as shown in Figure 23, in which "x" marks the point of irama change. This graph can be read in either direction; this type of irama change will be referred to as "Type 1."

2) Double or halve the bp without breaking the DR. This type of irama change, referred to as "Type 2," occurs frequently when changing from irama IV to III (Figure 24) and at points of structural transition in the free structures (Figure 25).

Type 1 irama changes do not have to take place at specific structural points nor do all the instruments operating at the DR need to change simultaneously (although they do so in close proximity). This type of change occurs only when the tempo of the DR becomes uncomfortably fast or slow for each individual musician. Type 2 irama changes usually take place at structurally important points, such as at a stroke of a gong, with all of the balungan instruments changing their density together. The perception of these two types of change is quite different due mainly to the way in which the tempo of the bp is changed, which is gradual in Type 1 and sudden

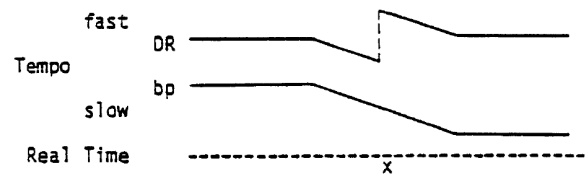

Figure 23. Type 1 Irama Change.

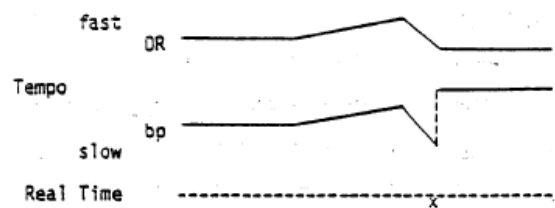

Figure 24. Type 2 Irama Change from Irama IV to III.

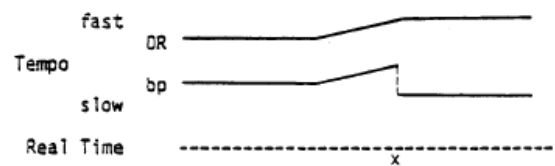

Figure 25. Type 2 Irama Change in Free Structures.

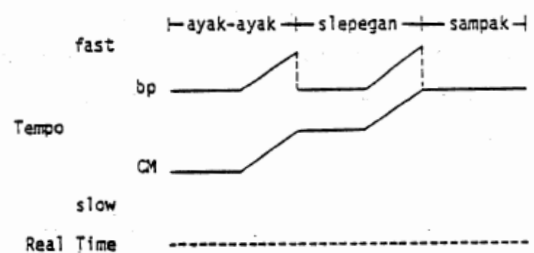

Figure 26. Free-Structure Changes

in Type 2. Both types of irama change provide smooth, seamless means of transitioning from one irama to the next without interrupting the continuous flow of the texture. This ability to move between different time frameworks and yet retain structural identity is an outstanding characteristic of Javanese gamelan performance practice.

Free-Structure Change

It is common in performance practice to hear the three free structures—Solonese Ayak-ayak, Slepegan, and Sampak, or

structure	type	kendelan	irama
ketawang	1	WN ¹	II
	2	PN ²	II
lancaran	1	N ²	I
ladrang	1	t ¹ N ¹ ; t ¹ N ² ; t ¹ N ³	III, IV
	1a	t ² N ¹	ssg, I
	2	PN ⁴	III, IV
	1-2	t ¹ N ² ; t ¹ N ³ ; PN ⁴	IV
	3	WN ¹	II
	4	N ³	III, IV
structures not using kempul:			
16 bp per kenongan	1	w ³ N ¹ ; w ³ N ²	III, IV
	2	N ³	III
	3	t ¹ N ¹ ; t ² N ¹ ; t ¹ N ² ; t ² N ²	III
	3a	t ³ N ¹ ; t ³ N ² ; t ³ N ³	III
32 bp per kenongan	1	w ⁷ N ¹ ; w ⁷ N ² ; w ⁷ N ³	III, IV
key:	The <i>kethuk</i> and <i>wela</i> superscripts refer to the stroke of <i>kethuk</i> or the <i>wela</i> in a <i>kenongan</i> , the <i>kenongan</i> superscripts refer to the <i>kenongan</i> in a <i>gongan</i> .		

Table 3. Kendelan Location.

their Yogyanese equivalents—played in a sequence from the largest, in terms of the number of bp per colotomic module (CM) to the smallest. The interesting aspect of this sequence is that in transitioning from one structure to the next, the CM never breaks its density but simply accelerates. In response to sudden *accelerandi*, the bp-density halves at each point of structural transition (Figure 26) to establish the new bp-to-CM relationship of each successive structure. The mechanics and tendencies of these free-structure changes are identical to those of Type 1 irama changes (compare Figure 26 to Figure 23, reading from right to left); the bp and CM in the free-structure changes behave respectively like the DR and bp in irama changes. The main difference between these two types of change is the level of the musical hierarchy on which they occur.

Structural Editing

Irama choices in performance flex the temporal dimensions of a piece and its colotomic structure, whereas structural editing choices interrupt the otherwise continuous flow of a piece and its structure in the course of a performance. Structural editing is manifested in gamelan in two ways: *kendelan* and *selingan*.

Kendelan

A *kendelan* (from *kendel*, “to stop, halt”), or *mawi mandeg* (“with stopping”), labels an action that momentarily suspends the normal tempo and structural flow of a piece in performance. *Kendelan* occur at internal structural points

such as at strokes of *kethuk*, *kempul*, *kenong*, and *wela*. This stopping is not the same as ending a piece (*suwuk*, “end”), which concludes the performance of a piece and always coincides with a stroke of *gong ageng*.

A *kendelan* is initiated with a special drum signal and is usually, but not always, completed with a short and sudden *ritardando*. *Kendelan* occur most frequently in pieces with strict structures, but musicians must know from experience the appropriate locations for them in any given piece. After a few seconds of silence, a vocalist will perform a short melodic phrase that concludes with the entire ensemble resuming the performance of the piece a few *balungan* beats later, with no change to the piece. In Appendix A, the structural locations of *kendelan* in recorded performances of forty-one pieces are detailed. This data is summarized in Table 3, where the various structural locations of stops are grouped by formal structure. Also listed are the irama in which each type of *kendelan* took place.

A few generalizations can be made about the occurrence of *kendelan*: they occur most frequently in pieces in *ladrang* structure and in the *ingghah* section of pieces with structures not using *kempul*, and they occur most often in irama III and IV. The correct location of *kendelan* in performance depends on the shared knowledge of the musicians about the treatment of each particular piece rather than on set locations associated with each formal structure.

Selingan

A *selingan* (“something interspersed”) is performed material of a contrasting nature that is infixed into the performance of a gamelan piece in a strict structure. The infix takes place at an internal structural point, often following a *kendelan*, and once the infixed material is completed a return is made to the initial piece.

While the nature of *selingan* varies greatly, there are four common types:

1) Pieces in strict and free structures. These include pieces in the *ladrang* and *ketawang* structures as well as a special category of pieces labeled *gendhing dolanan*, which are gamelan pieces of a light-hearted nature with texts enjoyed by children and adults alike.

2) *Macapat*, which is sung poetry performed by a solo vocalist with only the *gender barung* providing sparse, improvised accompaniment for pitch reinforcement. The poetry is in traditional Javanese verse structure and can be of substantial length, taking up to three or four minutes to deliver in a rhythmically free, ornate, and often melismatic manner.

3) *Palaran* (Solo) or *Uran-uran* (Yogya), which are *macapat* performed over a free-structured colotomic pattern without a *balungan*. A small subset of elaborating gamelan instruments (*gender barung*, *gender panerus*, *gambang*, *celempung*, and *suling*) fill out the texture, and the drummer controls the tempo and signals for phrase-ending punctuation (performed on the *siyem* or *gong ageng*) in accordance with the singer’s pacing.

4) Conversation, often of a humorous nature, that may be interspersed with singing and occasionally a *palaran*.

A few generalizations can be made about *selingan*:

- 1) part of the structure of the main piece usually, but not always, is deleted in the process of infixing material;
- 2) the infixed material and the main piece do not have the same formal structure; and
- 3) *selingan* occur relatively infrequently and are often associated with special treatments of particular pieces.

The effect of infixed material on the structure of a piece is one of diversion, and its inclusion in a performance would perhaps be agreed upon by the musicians beforehand.

Structural editing, as manifested by *kendelan* and *selingan*, affects structure in a different manner from *irama*. *Irama* expands and contracts structure from within by changing the duration of the *balungan*-pulse, while structural editing affects the structure externally by interrupting its cyclic flow to insert contrasting musical material. The application of *irama* and structural editing during performances adds dimensions of flexibility to gamelan music.

MELODIC ORGANIZATION IN PIECES WITH STRICT STRUCTURES

We turn now to a discussion of how the *balungan* of gamelan pieces with strict structures are organized at various structural and formal levels. Patterns of melodic repetition and contrast occur both between *kenongan* within *gongan* and between *gongan* in multi-*gongan* pieces, and *gongan* can be grouped into repeatable cycles that in turn become the building blocks of macro-level formal relationships.

Patterns of Kenongan Repetition Within the Gongan

The *balungan* of a *gongan* in any piece set to a strict structure is divided into phrases of equal length by strokes of the *kenong*, thus setting off melodic units parallel to the structural *kenongan*. The terms *gongan* and *kenongan* can denote both structural units as well as the melodic material (*balungan*) they contain.

The *balungan* of gamelan pieces are often not fixed. In printed sources as well as live performances one frequently finds differences in melodic detail of a piece's *balungan*, thus making a study of melodic organization on the consecutive-pitch level difficult. There is seldom found, however, any discrepancy between sources as to the melodic relationships between *kenongan* within a *gongan*. Thus a *gongan* may start out with a *kenongan* (here called *a*) that is repeated (another *a*), followed by a contrasting *kenongan* (called *b*) and another, different, contrasting *kenongan* (referred to as *c*). Sources will tend to agree that the *kenongan* pattern of this *gongan* is *aabc* even though the versions of *a*, *b*, and/or *c* might differ slightly.

Any *kenongan* can relate melodically to a previous *kenongan* in one of four ways:

<u>kenongan patterns</u>	<u># of occurrences</u>
abcd	23
aabc	23
aaab	14
abbc	12
abba	10
abac	5
abca	2
abcc'	1
aabb	1
aaba	1
abab	1
total	93

Table 4. Frequency of Kenongan-Patterns for Lancaran-s, Lancaran Mlaku-s, and Bubaran-s.

<u>kenongan patterns</u>	<u># of occurrences</u>	<u>basic kenongan patterns</u>	<u># of occurrences</u>
abcd	31	abcd	17
abcd*	2		
aa*bc	2		
aa*bb*	2		
aabc	18	aabc	34
aaba*	2		
aaa* ^b	6		
aa'bc	5		
aa'a' *b	1		
aa'bb*	2		
aaab	15	aaab	21
aa'a' *b	5		
aaaa*	1		
abbc	6	abbc	10
abb'c	4		
abca	3	a_a	9
abba	1		
abb'a	1		
abb'a'	1		
aaba'	1		
aba'a	2		
aabb'	2	aabb	5
aa'bb	1		
aa'bb'	2		
aaaa	2	aaaa	6
aa'aa'	1		
aa'aa''	2		
abcc	2	abcc	4
abcc'	2		
abac	1	a_a	3
aba'c	2		
abcb'	2	_b_b	3
aa*aa*	1		
total	131		131

Table 5. Frequency of Kenongan-Patterns for Lacrang-s.

- 1) it can be an exact repeat of a previous *kenongan*,
- 2) it can be a partial repeat of a previous *kenongan* with melodic differences occurring in its first half,
- 3) it can be a partial repeat of a previous *kenongan* with melodic differences in its second half, or
- 4) it can be totally contrasting.

The reason for differentiating between first- and

second-half melodic alterations is that any change in the first half of a kenongan is of less melodic consequence (in terms of melodic direction) than a change in its second half. This end-orientation is a basic characteristic of gamelan music. As a result, kenongan with first-half alterations will be considered related to kenongan that are exact repeats of previous kenongan, while kenongan with second-half alterations will be viewed as related to kenongan of contrasting material. Symbols are used here to notate these relationships:

- ' an alteration to the first half of the kenongan represented by the letter preceding it
- " a different first-half alteration to the kenongan represented by the letter preceding it
- * an alteration to the second half of the kenongan represented by the letter preceding it

These superscripts are additive, so, for example, a'^* denotes an end-alteration (*) to a preceding a' kenongan.

Melodic Form in Pieces with Four-Kenongan-per-Gongan-with-Kempul Structures

Pieces in the ladrang structure, which have eight-note-long kenongan, invite a more detailed level of melodic analysis than pieces in the lancar, lancar mlaku, and bubar structure that have kenongan only two or four balungan-notes long.

The kenongan-patterns of melodic (balungan) form of 93 different gongan from thirty pieces with lancar, lancar mlaku, and bubar structures are summarized in Table 4. Repetition of melodic material, when it occurs, is most frequently found between adjacent kenongan and either at the beginning of or in the middle of the gongan—seldom at the end. The notable exception among the frequently occurring patterns is *abba*, in which the repetition of *a* is separated by two kenongan. Regardless of this, *abba* still displays the standard characteristics of adjacent, repeated kenongan (*b*) in the middle of the gongan.

Although the kenongan-patterns for ladrang are more complex than those displayed in Table 4, they can be grouped into similar basic kenongan-patterns by applying two assumptions: 1) kenongan with first-half alterations are viewed as repetitions of the kenongan with which they share identical second halves, and 2) kenongan with second-half alterations are in contrast to the kenongan with which they share identical first halves. Therefore, the pattern $aa'a'b$ will be generalized to *aaab*, and the pattern $aaa*b$ to *aaab*. Detailed kenongan-pattern data gleaned from 131 different gongan belonging to forty-nine ladrang are presented in Table 5. The large number of patterns in this table demonstrates the variety of melodic relationships that can exist within a ladrang gongan, yet reinforces the same generalizations made about the first group of structures represented in Table 4.

<u>kenongan patterns</u>	<u># of occurrences</u>	<u>basic kenongan patterns</u>	<u># of occurrences</u>
aabc	27	aabc	57
aaa*b	18		
aa'bc	8		
aa'a'*b	4		
abcd	19	abcd	34
abb*c	3		
aa*bc	12		
aaab	15	aaab	31
aaa'b	1		
aa'a'b	12		
aa'a'a'*	1		
aa'a"b	2		
abbc	14	abbc	27
abb*b*	2		
abb'c	10		
abb'b*	1		
abca	2	a_a	9
aa*ba	1		
abca'	1		
abba	2		
aaba'	2		
aba'a"	1		
aaaa'	3	aaaa	4
aa'a'a"	1		
aba'a'*	1	a_a_	2
aa*a'b	1		
aa*bb'	1	abcc	1
abcb'	1	abcb	1
total	166		166

Table 6. Frequency of Kenongan-patterns for Pieces with Four Kenongan-s per Gongan, Not Using Kempul.

pattern	bp per gongan		
	8, 16	32	64, 128 256
abcd	24.7	28.3	20.5
aabc	24.7	26.0	34.3
aaab	15.1	16.0	18.7
abbc	12.9	7.6	16.3
other	22.6	22.1	10.2
total	100.0	100.0	100.0

Table 7. Percentages of Total Gongan-s Surveyed With Most Common Kenongan-Patterns.

Proportionally, the patterns *abcd*, *aabc*, *aaab*, and *abbc* are approximately the same for both sets of pieces, while the number of occurrences of *abba* is considerably fewer in ladrang pieces. Thus, pieces with four-kenongan-per-gongan-with-kempul structures display a strong tendency towards similar patterns of melodic organization within the gongan.

Melodic Form in Pieces with Four-Kenongan-per-Gongan-without-Kempul Structures

Data on the kenongan-patterns of melodic (balungan) form of 166 different gongan taken from fifty-two pieces with four-kenongan-per-gongan-without-kempul structures is presented in Table 6. Although the same patterns that had the greatest presence in pieces summarized in Tables 4 and 5 also dominant here, the pattern *aabc* is by far the most common in this group of pieces. Not only is the basic kenongan-pattern *abcd* proportionately less frequent than in the pieces of the other four-kenongan structures, but the pattern *aa*bc*, which demonstrates at least partial repetition and a resemblance to *aabc*, is considerably more frequent than in those other four-kenongan-per-gongan pieces. This greater overall preference for repeated kenongan-patterns can, at least in part, be attributed to the larger gongan size of these structures.

The results of the preceding survey of balungan kenongan-patterns for structures with four kenongan-per-gongan are summarized in Table 7. Given under each structural group is the percentage of the total number of gongan surveyed for each of the four most common patterns, as well as the total percentage of the less frequent patterns.

Taking into consideration the contents of Tables 4-7, several generalizations may be made concerning the basic melodic organization of the balungan within the gongan of pieces with four-kenongan-per-gongan structures:

- 1) kenongan repetition, both partial and complete, is very common in these structures;
- 2) repetition most frequently occurs between adjacent kenongan of a gongan;
- 3) repeated kenongan are most frequently located in the first three kenongan of a gongan;
- 4) repeated kenongan are infrequent in the final two kenongan of a gongan;
- 5) patterns beginning and ending with the same kenongan occur but are infrequent;
- 6) the most common kenongan-patterns involving repetition are *aabc*, *aaab*, and *abbc*, in that order; and
- 7) the larger the structure the greater the frequency of these most common patterns.

Melodic Form in Pieces with Two-Kenongan-per-Gongan-with-Kempul Structures

The balungan of 207 gongan from forty-five pieces in the ketawang structure were examined for patterns of kenongan repetition. With only two kenongan per

pattern	# of occurrences
ab	187
aa	11
aa*	7
aa'	2
total	207

Table 8. Frequency of Kenongan-Patterns for Ketawang-s.

two-kenongan pattern	infixes kenongan-s	becomes the four-kenongan pattern
	bc	abcd
"a" and a contrasting kenongan	ab	aabc
	aa	aaab
	bb	abbc

Figure 28. Derivation of Four-Kenongan Patterns.

gongan in this structure, there exists only four possible formal patterns. The pattern *ab* was found in nearly ninety percent of these gongan, completely dominating the patterns displaying partial or complete kenongan-repetition (Table 8).

The preference for ending a gongan with melodic material different from its beginning also appeared in four kenongan-per-gongan structures. In fact, the most common four-kenongan patterns (*abcd*, *aabc*, *aaab*, and *abbc*) can be derived from the two-kenongan pattern *ab* by infixing two new or repeated kenongan (Figure 28).

Melodic Form in Pieces with Two-Kenongan-per-Gongan-without-Kempul Structures

The balungan of sixty-two gongan from eleven pieces in the ketawang gendhing structure were analyzed for patterns of kenongan repetition (Table 9). Although there is a proportionally greater number of occurrences of the patterns *aa*, *aa**, and *aa'* than found in pieces in the ketawang structure, the pattern *ab* is still clearly dominant.

In summarizing the form of the balungan in pieces with two kenongan-per-gongan structures it can be said that melodic repetition of kenongan, whether partial and complete, is rare, though more frequent in pieces with larger structures than with ketawang pieces.

Melodic Relationships of Gongan Within Pieces

The balungan of 187 pieces in a range of strict structures were analyzed for melodic relationships between their gongan and for how those gongan are organized into repeatable gongan-cycles. Tables 12-16 in Appendix E

<u>pattern</u>	<u># of occurrences</u>
ab	49
aa*	6
aa	4
aa'	3
total	62

Table 9. Frequency of Kenongan-Patterns in Ketawang Gendhing-s.

contain the formal designs of this group of pieces. A formal design is a distilled representation of a piece's macro melodic organization and of its potential to produce large-scale formal relationships across multiple realizations. In my attempt to capture the awareness competent gamelan performers command of the formal potential of a piece, I have made some generalizations about the nature of the melodic relationships between gongan of multi-gongan pieces, also exploring the variables of repetition of melodic material in pieces.

The balungan of most strict-structure gamelan pieces is distributed over multiple iterations of its gongan structure, thus creating the possibility of melodic relationships between its gongan. Any gongan can relate to a previous gongan in one of four ways. It can be:

- 1) an exact repetition of a previous gongan;
- 2) a partial repeat of a previous gongan with melodic differences occurring in its first half;
- 3) a partial repeat of a previous gongan with melodic differences occurring in its second half; or
- 4) totally contrasting.

The melodic effects of first- and second-half alteration on the gongan level are parallel to those discussed for kenongan. Partial and complete repetition of melodic material on the gongan level is more common in pieces with small structures (those using kempul) than in pieces with large structures (those not using kempul). Partial and complete repetition most frequently occurs between adjacent gongan.

Three distinctive types of melodic relationships found between gongan of some pieces need to be introduced:

- 1) *Mulur* (lit. to stretch, expand) is a term applied to the irama III and IV versions of balungan, most often for pieces in the ladrang structure. The balungan of many pieces in these irama might be exactly the same as in other irama, but in some pieces the balungan is altered. The density of the balungan notes in a mulur gongan is frequently twice, and occasionally quadruple or half, that of the structural balungan-pulse. A mulur gongan, regardless of balungan alterations, is always closely related to the regular balungan, especially in terms of the melodic pitches sounded at structurally important points.

- 2) *Umpak minggah* (transition to the inggah section, also called *pangkat ndawah*) is a melodic alteration that

occurs during the transition from the merong section to the inggah section of a piece's structure. The last one-half to two kenongan of the final merong gongan is altered, quite frequently to match the balungan located in the corresponding position of the inggah section that follows.

- 3) Inter-gongan repetition of kenongan. In a substantial number of kenongan repetitions surveyed, the first kenongan of a gongan was a partial or exact repetition of the final kenongan of the gongan immediately preceding it. This occurs in pieces in all of the strict structures. In two kenongan-per-gongan structures this kind of repetition is as common as the various "inner-gongan" patterns discussed previously. Although found less frequently in the four kenongan-per-gongan structures, more variants exist. Two of the more common patterns are:

First gongan: *aabc*
 Second gongan: *ccde*

and

First gongan: *aaab*
 Second gongan: *bbbc*

This latter pattern is sometimes sequenced through all of the gongan of a piece:

First gongan: *aaab*
 Second gongan: *bbbc*
 Third gongan: *cccd*
 Fourth gongan: *ddda*

Grouping of Gongan into Repeatable Gongan-Cycles

The degree of flexibility available to gamelan musicians in the course of realizing a piece is much greater than that allowed players in a symphony orchestra. This flexibility, apparent in many aspects of gamelan music, is perhaps nowhere more obvious than in the range of formal relationships possible in multiple performances of any given piece. The number of times each section or the entire piece is repeated, how many and in which irama it is played, and what kind—if any— structural editing takes place are the most important variables that are left up to the performers and that interact to create a variety of possible formal outcomes. Thus, to do justice in a formal sense to a gamelan piece, one must examine the formal possibilities it possesses as well as the formal outcome of each performance.

One hundred eighty-seven strict-structure pieces were examined for cycles of repeated gongan as well as for melodic relationships between gongan. The results, presented in Appendix E, are expressed as formal designs that, when combined with the information pertaining to irama and structural editing choices that are left up to the performers, begin to give a fairly complete idea of the complexity of the realization process and the range of possible formal relationships for any one gamelan piece.

A presentation of the variables of repetition of melodic material in these gamelan pieces uses these symbols:

- : :
 - ; ;
 - ⁿ
 - ()
 - /
- The gongan enclosed by colons constitutes a main gongan-cycle that in performance can be played either once or repeated.
- The gongan enclosed by semicolons constitutes a repeatable gongan-cycle contained within a main gongan-cycle that, likewise, can be played once or repeated a number of times.
- The gongan with this superscript are played only upon a special melodic signal from one of the elaborating instruments; these are called the *ngelik* section of a piece.
- The gongan and repetition patterns enclosed by parentheses are optional.
- The slash separates main gongan-cycles that have different colotomic patterns, e.g. merong section or inggah section of a piece.

Gamelan pieces in the strict structures always have a section (or sections) of one or more repeatable gongan that can be played either once or repeated a number of times. All of the pieces surveyed belong to one of two basic formal schemes: 1) schemes with one main, repeatable gongan-cycle; or 2) schemes with two main, repeatable gongan-cycles.

A repeatable gongan-cycle is most commonly from one to five gongan in length (sometimes even more) and may be preceded or followed by other gongan that are played only once. Gonggan-cycles with *ngelik* gongan may not have the same number of gongan with each repeat, a possibility not present in cycles without a *ngelik* gongan, which for some pieces is optional in performance.

Formal schemes with One Repeatable Gonggan-Cycle

Pieces with one repeatable gongan-cycle will have one of two formal schemes: 1) one repeatable gongan-cycle without *ngelik* gongan, or 2) one repeatable gongan-cycle with *ngelik* gongan. The first scheme can be expressed as:

:_:

which is interpreted as a cycle consisting of one or more gongan that may be played once or a number of times in a performance. This formal scheme is most commonly found in pieces with the structures *lancaran*, *lancaran mlaku*, *bubaran*, or *ladrang*.

The second scheme is diagrammed as:

;;_:_n:

Within the repeatable cycle of pieces with this scheme there is a gongan, or multiple gongan, that can be played either once or, theoretically, any number of times (seldom more than twice in practice) before the *ngelik* signal is given and the *ngelik* section played. After the *ngelik* section, a return is made to the beginning of the entire cycle. Most pieces in the *ketawang* structure have this formal scheme, as well as some pieces in the *ladrang* and *lancaran* structures. The *ngelik* section of *ketawang* pieces is typically three gongan in length, while pieces in the *ladrang* structure using this scheme have *ngelik* sections of one or two gongan.

Performances of pieces with one repeatable gongan-cycle generally conclude (*suwuk*) at the end of the repeatable cycle, although some pieces can *suwuk* in any of the gongan within the cycle. A few pieces must end in a specific gongan either within the cycle or, very rarely, a special gongan outside of it. This *suwuk* placement variability can be, at least in part, explained by the fact that these pieces are often used to accompany dance and theater

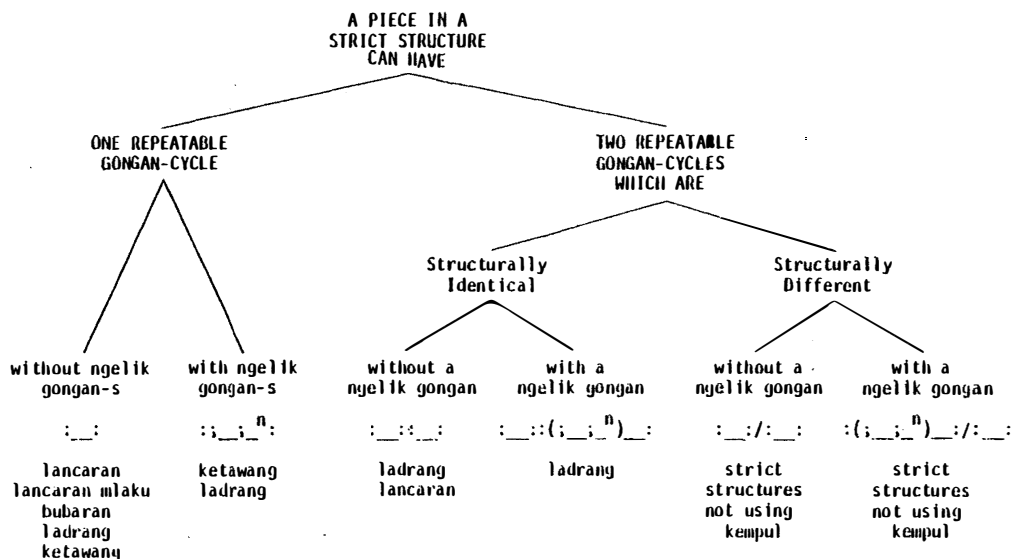

Figure 29. Formal Schemes for Pieces with Strict Structures.

that require them to end at a dramatically satisfactory point that could occur at any stroke of gong ageng in a piece.

Formal Schemes with Two Repeatable Gongan Cycles

Pieces with two repeatable gongan-cycles will belong to one of four formal schemes:

- 1) two repeatable gongan-cycles that are structurally identical and without a ngelik gongan;
- 2) two repeatable gongan-cycles that are structurally identical with a ngelik gongan in the second cycle;
- 3) two repeatable gongan-cycles that are structurally different and without ngelik gongan; or
- 4) two repeatable gongan-cycles that are structurally different with a ngelik section in the first cycle. These schemes are diagrammed as follows:

:_:::_:

This indicates pieces with two structurally identical gongan-cycles, not including a ngelik gongan. Ladrang and lancaran structures belong to this scheme. The main difference between the two cycles is the irama in which they are performed, the first cycle being in a faster irama than the second. In some pieces with the ladrang structure the second cycle is the mulur gongan. Although the first cycle can be returned to after the second cycle, it is more common not to make this return and simply suwuk in the second section.

:_:::(;_n)_:

Some ladrang pieces have this scheme of two structurally-identical gongan-cycles with a ngelik gongan in the second cycle. The main difference between these two cycles is irama, with the first cycle performed in irama I and II, the second in irama III and possibly IV. The ngelik gongan, which is optional, will always be preceded and followed by the playing of at least one non-ngelik gongan.

:_:/:_:

This scheme is shared by many pieces with two- and four-kenongan-per-gongan structures not using kempul. The cycle to the left of the slash is the merong section, and to the right, the inggah section. The structural distinctions between these two cycles/sections of a piece can be slight, such as the number of kethuk strokes per kenongan in each, or marked, such as having a different number of balungan-pulses per gongan. The two cycles of some pieces using this scheme can also be differentiated from one another by irama treatment. The merong section is not returned to once the inggah section is entered.

:(;_n)_:/:_:

This formal scheme is similar to the previous one but includes an optional ngelik sub-cycle in its first section. If performed, the ngelik gongan is always preceded and followed by at least one gongan of

		TRANSCRIPTION			
		3	4	5	6
MODAL ORGANIZATION	tuning system pathet	pl br	s1--pl--s1 nyr br nnyr	s1 9	s1-pl-s1 9 6 9
# OF GONGAN-S	in irama seseg	1		1	
	in irama I	7			4
	in irama II	1	1	3	4
	in irama III	3	4	4	4
	in irama IV	1	1		2
total	13	6	8	14	
# OF NGELIK GONGAN-S	in irama III		1		
	in irama IV	1	1		1
	total	1	2	0	1
# OF KENDELAN-S	in irama seseg			2	
	in irama I				2
	in irama IV	3	2		3
total	3	2	2	5	
SELINGAN	infixes material	palaran			
PERFORMANCE TIME	first cycle	3:17	:39	2:11	4:06
	second cycle	11:46	10:22	6:55	13:04
	total	15:03	11:01	9:06	17:10

Table 10. Data Drawn From the Pangkur Transcriptions.

the non-ngelik cycle. The merong section is not returned to once the inggah section has begun.

Gamelan musicians are guided in their performance of any given piece by their shared knowledge of its formal organization, which involves the ordering of essential and optional melodic material (balungan) into units (gongan and groupings of gongan) that can be repeated within constraints. An attempt has been made here to extract from the analysis of the formal organization of a number of pieces (their "formal designs") a small set of schemes that might be thought of as the syntax of macro-level formal relationships for this tradition (Figure 29).

PERFORMANCE PRACTICE FLEXIBILITY

A comparison of four recorded performances of a single gamelan piece—*Ladrang Pangkur*—illustrates how the variables of gamelan performance practice interact to create considerably different formal results. Of the many performances of *Pangkur* available on commercial recordings from Java, four have been chosen for the variety of performance options their performers made while realizing the piece and for their strikingly different formal outcomes. (Transcriptions of these four performances are found in Appendix C as Transcriptions 3, 4, 5, and 6, abbreviated T3, T4, T5, and T6, respectively in the commentary and figures to follow.)

Ladrang Pangkur has the two-gongan-cycle

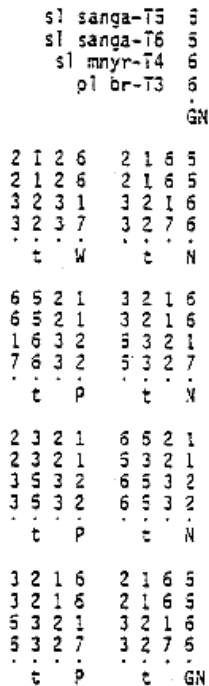

Figure 30. Comparison of the Balungan-s for the Regular Gongan of Pangkur.

formal scheme :__:(;__;_n)__ and its formal design is :A: ;Am*Bn;Am:. Table 10 is a compilation of mostly quantifiable information extracted from the four performances and illuminates the various facets of the process by which gamelan pieces are realized.

Tuning Systems and Balungan

Each of the two tuning systems used in gamelan music has three main modes, called *pathet*.

Laras Slendro	Laras Pelog
<i>pathet nem</i>	<i>pathet lima</i>
<i>pathet sanga</i>	<i>pathet nem</i>
<i>pathet manyura</i>	<i>pathet barang</i>

Some gamelan pieces, including *Pangkur*, can be realized in either laras and in more than one pathet within the same tuning system. *Pangkur* can be realized in pathet sanga or pathet manyura in laras slendro, and in pathet nem or pathet barang in laras pelog.

Figures 30, 31, and 32 present, respectively, the regular (A), mulur (A^m), and ngelik (Bⁿ) balungan of *Pangkur* as played in the four transcribed performances.

Figure 30 compares the balungan for the regular gongan of *Pangkur* as found in the four performances. This

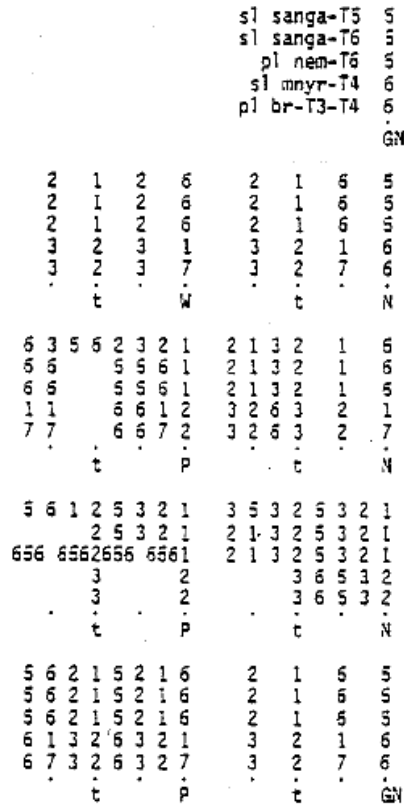

Figure 31. Comparison of the Balungan-s for the Mulur Gongan of Pangkur.

	s1 sanga-T6	1	
	s1 mnyr-T4	2	
	pi br-T4	2	
	pi br-T3	2	
		GN	
1	3 3	2	2 3 5 6 3 5
2	5 3 2 3		3 5 6 1 5 6
2	4 3 2 3		3 5 6 7 5 6
2	4 3 2 3		3 5 6 7 5 6
	t	W	t
1 1	3 2 1 6	2 1 5 3	2 3 2
2 2	()) 5 1 6 5 3	
2 2	4 3 2 7	3 2 6 5 7 5 3	
2 2	()) 5 7 6 5 3	
	t	t	N
2 3 5 6 1 5	6 1 5	2 3 5 6 5 3 2 1	
3 5 ()) 6	3 5 6 1 5 5 3 2	
3 5 6 7 5 6		3 5 6 7 6 5 3 2	
3 5 ()) 6	3 5 6 7 6 5 3 2	
	t	t	N
5 6 2 1 5 2 1 6		2 1 6 5	
5 1 3 2 6 3 2 1		3 2 1 6	
6 7 3 2 6 3 2 7		3 2 7 6	
6 7 3 2 6 3 2 7		3 2 7 6	
	t	t	GN

Figure 32. Comparison of the Balungan-s for the Ngelik Gonggan of Pangkur.

is the only gongan in the first cycle of *Pangkur's* formal scheme and it can be performed in irama seseg, I, and II. Transcriptions 3 and 4 are basically transpositions of the Transcription 6 balungan. Transcriptions 5 and 6 are both in slendro pathet sanga and are identical except for two pitches found in the third kenongan. The balungan for Transcriptions 3 and 4 are basically the same except pitch 1 in slendro pathet manyura becomes pitch 7 in pelog pathet barang.

Figure 31 compares the various mulur balungan found in the performances. The mulur gongan is the primary gongan in the second cycle of *Pangkur's* formal scheme and can be performed in irama III and IV. In general, the balungan found in Transcriptions 3 and 4 are transpositions of those found in Transcriptions 5 and 6, although a number of versions exist for the second and third kenongan. However, the pitch sounded at the end of any given gatra does not vary from one balungan interpretation to the next.

Figure 32 compares the balungan of the various ngelik gongan, an optional gongan in the second cycle of the *Pangkur* formal scheme that can be performed in irama III and IV. The first two-and-one-half kenongan display considerably different interpretations of the balungan, although there are again no discrepancies found at the end

of gatra. Pitch 4 is sometimes used instead of pitch 5 in pelog pathet barang.

The above comparison suggest that performers have some degree of flexibility in interpreting the melodic dimension of a piece, but whichever interpretation is used for any one performance must be agreed upon by all the performers.

In two of the performances a change is made from one tuning system to the other in the course of the performance. This is called *molak-malik* (lit. to keep changing) and occurs only between pathet settings of a piece that share the same gong-tone and, for the most part, the same pitches throughout. Examples of *molak-malik* are found in Transcription 4 (slendro pathet manyura to pelog pathet barang and back to slendro pathet manyura) and Transcription 6 (slendro pathet sanga to pelog pathet nem and back to slendro pathet sanga).

Laras and pathet choice is therefore another aspect of performance practice flexibility. The performers must know in which laras and pathet a piece can be performed and if it is traditionally acceptable to *molak-malik* between them. With this knowledge, the performers can choose a laras-pathet option for a performance of a piece and whether to stay in that laras-pathet choice throughout the entire performance (as in Transcriptions 3 and 5) or to *molak-malik* (as in Transcriptions 4 and 6). In the latter case, obviously contrasting sections are created on a macro-level which are not present in performances that remain in the same laras-pathet combination throughout.

	normal	ladrang	GN
	T3 kebar	variant	GN
	T6 kebar	variant	GN
t	W	t	N
t	P	P t	N
t	P	P t	N
t	P	t	N
t	P	P t	N
t	P	P t	N
t	P	t	GN
t	P	P tP	GN
t	P	Pt P	GN

Figure 33. Ladrang Structure and Kebar Variants.

Structure

Pangkur is cast in the 32-balungan-pulse ladrang colotomic structure with four eight-beat-kenongan-per-gongan using kempul (Figure 14). When performing, Javanese musicians have available to them for certain pieces in the ladrang structure, including *Pangkur*, a treatment called *kebar*, which originates in the world of Javanese dance where such pieces accompany lively sections of certain dances. Kebar treatment is performed only in irama I and includes the use of specific drumming patterns, specific functions in certain elaborating and melodic instruments, and a variant of the ladrang colotomy that includes additional kempul strokes. Musicians in T3 and T6 chose to apply the kebar treatment to their performance. Each of these performing groups used a slightly different variant of the ladrang structure for their kebar treatment, and these are compared to the regular ladrang structure in Figure 33. The two variants differ from one another only in the last four beats of the gongan, when the placement of a kempul stroke creates a syncopated rhythmic relationship with the balungan-pulse. Performers choose whether or not to invoke the kebar treatment in a performance, but when they decide to do so it articulates a section within the performance that stands in clear contrast to other sections of the performance, therefore contributing to the perception of the macro-level formal organization of the performance.

Irama and Irama Transitions

Pangkur can be performed in all five irama: the regular gongan in irama seseg, I, II, and the mulur and ngelik gongan in irama III and IV. Table 10 lists the number of gongan in each irama found in each of the four performances. Some transitional gongan passed through as many as three irama that, like all of the gongan in these performances, are listed in Table 10 under the irama that was in effect for the greatest part of the gongan. Two important points reinforced by this data are: 1) although *Pangkur* can be performed in all five irama, it does not have to be performed in all of the irama in each performance, and 2) choices such as which irama are performed and how many gongan are played in each of them are variables left to the performers.

Irama changes are abundant throughout these performances. Type 1 irama changes (Figure 23) are found in each performance, most commonly from a faster bp irama to a slower bp irama (e.g., seseg to I, I to II, etc.), although one example of an irama change in the opposite direction is found in the final gongan of Performance 5 (irama III to II). Type 2 irama changes (Figure 24) occur in Performances 3, 4, and 6 when changing from irama IV to irama III, in Performance 5 from irama I to irama seseg, and in Performance 6 from irama II to irama I.

The combined effect of irama choice and repetition of gongan made by the performers resulted in vastly different cycle lengths; see "Performance Time" in Table 10. Additionally, pronounced differences are found in these four

regular	3 2 3 7	3 2 7 6
mulur	3 2 3 7	3 2 7 6

	t W	t N
	7 6 3 2	5 3 2 7
77	6672	3263 2 7

	t P	t N
	3 5 3 2	6 5 3 2
	. 3 . 2	. 3 6 5 3 2

	t P	t N
	5 3 2 7	3 2 7 6
67326327	3 2 7 6	

	t P	t GN

Figure 34. Comparison of the Regular and Mulur Balungan-s for Ladrang Pangkur.

mulur	3 2 7 6
ngelik	3 2 6 7 2

	t GN
	3 2 3 7
2	4 3 2 3

	t W
	77 6672
22	4327

	t P
	3 2
	3 5 6 7 5 6

	t P
	6 7 3 2 6 3 2 7
6 7 3 2 6 3 2 7	3 2 7 6

	t P

Figure 35. Comparison of the Mulur and Ngelik Balungan-s for Ladrang Pangkur.

realizations of *Pangkur* between the proportion of time spent in the first gongan-cycle of the piece compared to that in the second gongan-cycle.

Structural Editing

All four of the performances had kendelan (Table 10). Of the twelve kendelan executed by the performers, two each took place in irama seseg and I, and the other eight in irama IV. I have never heard a kendelan in Irama II during a performance of *Pangkur*, and while tradition permits kendelan in irama III, none occurred in these particular performances.

At the point of the final kendelan in performance T3 a palaran is inserted, the only example of structural infix in these four performances of *Pangkur*. The end of the final phrase of the palaran coincides with the continuation of *Pangkur* in irama III. Thirty of the thirty-two balungan

pulses in this gongan of *Pangkur* are skipped as a result of this structural infix.

Melodic Organization

The balungan of both the regular and the mulur gongan of *Pangkur* have the kenongan pattern *abca'*. The mulur gongan, regardless of the various renditions found in these transcribed performances, is an interesting combination of melodic repetition, elaboration, and abstraction of the regular gongan of *Pangkur*, as shown in Figure 34 for the pelog pathet barang balungan. The balungan pitches at every stroke of gong ageng, kenong, and kempul (and wela), as well as half of the strokes of kethuk, are the same in both versions, confirming the melodic similarity between these two balungan. Performers consider the regular gongan (A) to be derived from the mulur gongan (A^m).

The ngelik gongan has the kenongan pattern *defa'*. To get to the ngelik from the mulur gongan, the pitches in the last two balungan-pulses of the mulur gongan are altered to arrive at a different gong-tone. The ngelik balungan differs from the mulur balungan until the last two balungan-pulses of the third kenongan; from that point on they are identical (Figure 35).

The balungan of *Pangkur* is melodically very unified, since the regular and mulur gongan are basically the same (the former derived from the latter), and since the ngelik gongan, although obviously contrasting, nonetheless has the same final kenongan as the mulur gongan.

The formal scheme of *Pangkur* has two repeatable gongan-cycles. The first cycle consists simply of one gongan, the regular gongan (A); this can be played either once or several times and expressed as (:A:). The second gongan-cycle of *Pangkur* has one basic gongan, the mulur gongan (A^m), as well as the optional ngelik gongan (Bⁿ). The second gongan-cycle, in its simplest form, can be expressed as (:A^m:). With the possible inclusion of the ngelik gongan, however, the form of the second cycle is expressed as (;A^m*Bⁿ;) with A^m* representing the mulur gongan with the alteration leading to the ngelik gongan, Bⁿ representing the ngelik gongan, the semicolons representing the possibility of repetition, and the parentheses the fact that it is optional. Thus, *Pangkur*'s second gongan-cycle can be expressed, with all its possibilities, as (:A^m*Bⁿ;)A^m:. Table 11 presents the

	first gongan-cycle	second gongan-cycle		total # of gongan-s
	:A:	:(;A ^m *B ⁿ ;)A ^m :		
T3	9	1	2	13
T4	1	2	1	6
T5	4		4	8
T6	8	1	4	14

Table 11. Gongan Repetition in the Transcribed Performances of Ladrang *Pangkur*.

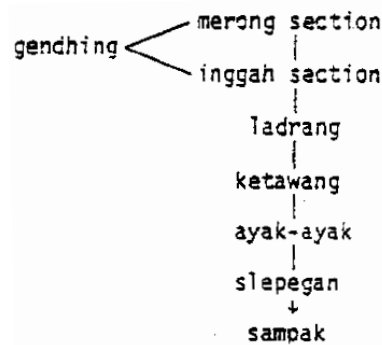

Figure 36. Sequence of Structures Found in the Talu.

entire formal design of *Pangkur* and the number of times each of its gongan was performed in the four performances. One time through (;A^m*Bⁿ;) is two gongan long, two times through is four gongan long. The range in terms of the number of gongan in each section attests to the flexibility of performance practice in gamelan music.

The preceding discussion of the structural, melodic, and formal organization of a gamelan piece and the consequences of choices made by performers in the course of realizing it illustrates the flexible nature of Central Javanese gamelan music and performance practice. The overall formal shape of a gamelan piece is created anew with each performance, the result of interacting musical components being combined in various ways to produce endless renditions of the same piece.

STRUCTURAL ORGANIZATION IN SEQUENCES OF PIECES

Gamelan pieces are frequently strung together in performance to form sequences of pieces. Although no written principles or guidelines exist to dictate how pieces are sequenced, after hearing numerous performances certain modal (pathet) and structural relationships appear recurrent and significant. For instance, with few exceptions, all of the pieces in any one sequence belong to the same pathet.

How the structures of the pieces forming a sequence are ordered and connected is somewhat complex. The information presented here is drawn from forty-four recorded performances identified and summarized in Appendix F.

Talu Sequence

The most elaborate sequence of pieces found in gamelan music is the one used for the *tal* (overture) to theatrical productions such as *wayang kulit* (shadow puppet plays) and *wayang orang* (human actor-dancer plays). Although different combinations of pieces can be used for a talu, their order in the sequence appears to be determined by their structures (Figure 36). The first piece in this sequence will have a four-kenongan-per-gongan-without-kempul

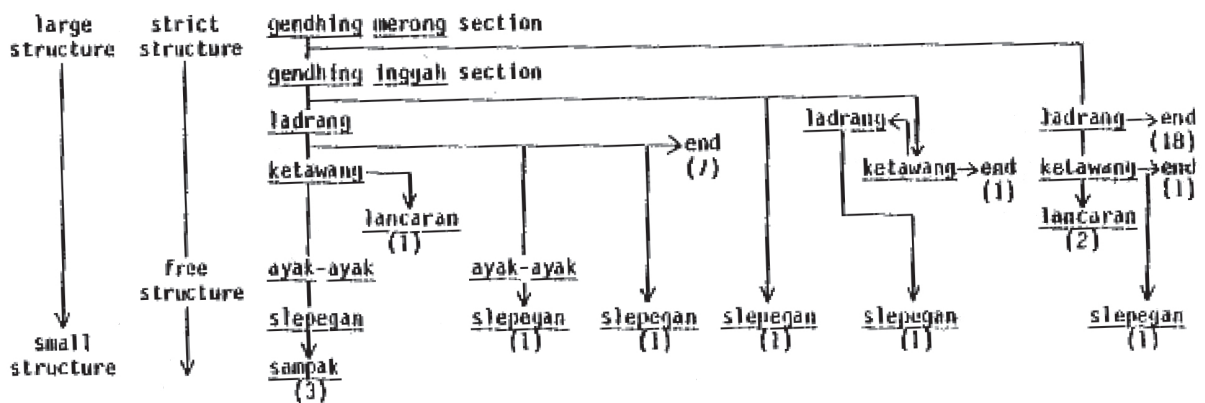

key: the numbers in parentheses indicate the number of performances found in the discography for each particular sequence

Figure 37. Talu and Talu-Related Sequences.

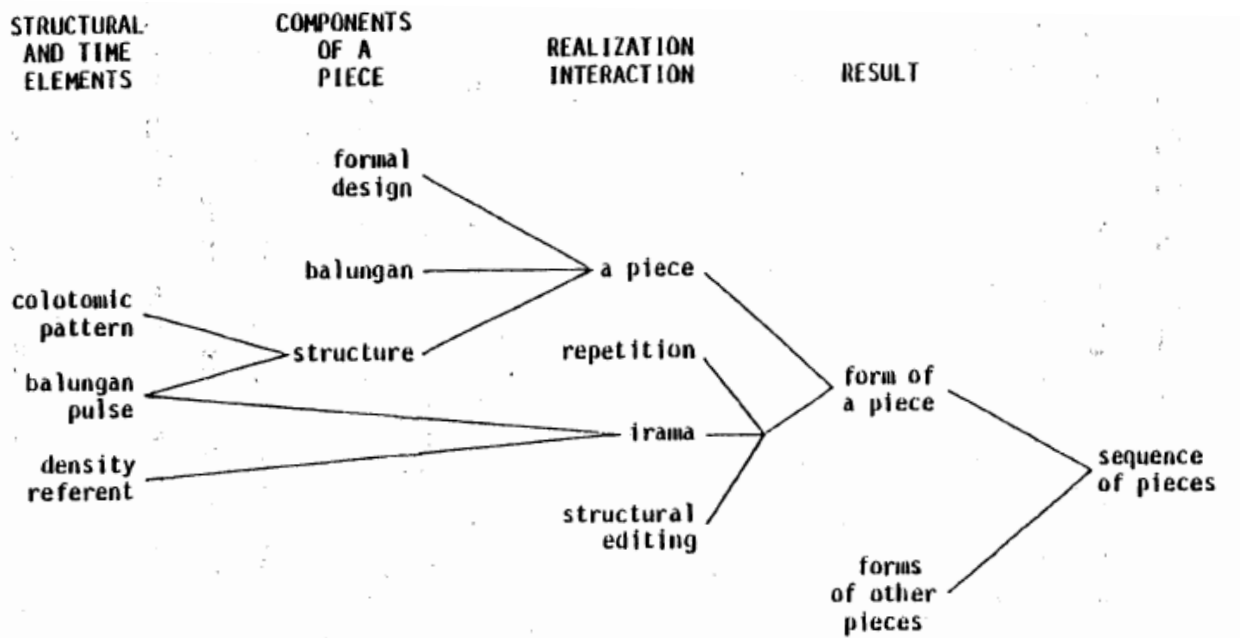

Figure 39. The Formal Process in Gamelan Music.

structure with either 128 or 64 balungan-pulses per gongan in both of its two repeatable gongan cycles (merong and inggah). This is followed by a piece with the ladrang structure (32 bp per gongan) and then by a piece with the ketawang structure (16 bp per gongan). Following the ketawang structure are pieces in the free structures of ayak-ayak, slepegan, and sampak. All of the pieces in this sequence are connected without interruption.

Two important tendencies are apparent in the talu sequence:

- 1) a progression from pieces with large structures to pieces with small structures, and
- 2) the sequence begins with pieces in the strict structures and ends with pieces in the free structures.

These tendencies seem to be important organizing principles for not only the talu, but also for the sequencing of pieces in other settings, including *klenengan* (gamelan performance for listening pleasure).

Talu-Related Sequences

Of the forty-four performances examined, only three were talu for wayang kulit performances with the sequence of structures diagrammed in Figure 36. However, the sequence of structures found in thirty-five of the remaining forty-one medleys of pieces displayed some degree of relationship to the talu sequence and will be called “talun-related sequences.”

A variety of talu-related structural sequences were found in the corpus (Figure 37). The left side of the chart lays out the talu sequence and its structural tendencies, while all of the encountered deviations from this sequence are mapped out on the right. All but one of the eleven talu-related sequences represented follow the tendencies of the talu sequence; in the one exception a ladrang was played after a ketawang. Three of the performances contained pieces in the lancaran or lancaran mlaku structures. Although pieces in these structures are not found in talu, these pieces are positioned in their respective medleys where one might expect according to the structural tendencies of talu sequences—at the end of pieces in strict structures and before pieces in free structures.

Although the underlying tendencies of the talu sequence are reinforced in these related sequences, the only element they all include is the merong section of a piece in a four- or two-kenongan-per-gongan-without-kempul structure. After the merong section of the initial piece is played, either its inggah, the inggah of another piece, or a ladrang follows. The possibilities after this point become more numerous, including skipping one or more of the structures of the talu sequence and frequently ending the sequence before all of the possible structures are used (five of the sequences do not include any pieces in the free structures).

The means by which the pieces in talu-related sequences are connected are occasionally more complex than in the talu sequence itself. Whereas the talu sequence is performed without interruption between its constituent pieces, it is not uncommon for some kind of interruption to

the flow of performance to occur in talu-related sequences. These typically occur somewhere after the first two structures of a sequence and in one of two ways:

1) a piece in the sequence is ended (suwuk) and is immediately followed by the introduction (buka) of the next piece in the sequence; or

2) a piece in the sequence is ended (suwuk) and is followed by a solo vocal piece of substantial duration that either leads directly into the next piece of the sequence or is followed immediately by the buka for the next piece.

Regardless of the nature of the interpretation, it is no more than a temporary break in the otherwise continuous flow of the music. Such interruptions are similar in their effect to kendelan and structural infix.

The individual pieces within a sequence are subject to the variables of structural flexibility (irama and structural editing choices) and melodic repetition. As these play out in the realization of each piece in a medley, they also contribute to the perception of the overall form of the medley itself.

Other Sequences

Only six of the forty-four performances in the corpus did not have talu or talu-related sequences (Figure 38). Four of these performances consisted simply of two ladrang, while the remaining two began with a piece in the lancaran structure followed by a ladrang and returning to the initial lancaran; one of these performances after this point went to another piece in the ladrang structure. The first of these sequences is heard only in *klenengan* performances, its two pieces joined sequentially simply because they complement one another musically. The latter two sequences reveal influences from the world of Javanese dance, where gamelan music as accompaniment provides temporal frameworks into which movement is choreographed. The basic sequence of lancaran to ladrang (or sometimes ketawang) to lancaran pieces is used for the accompaniment to several dances such as *Gambiranom*, *Klana*, *Eko Prawiro*, and others.

Joining pieces into a medley is a common occurrence in Javanese gamelan performance. It appears that gamelan musicians, when arranging medleys for *klenengan* performance, are guided to at least some degree by two distinct models—either by the talu or by dance accompaniment. Regardless of which model is guiding the sequence, in performance the constituent pieces comprising the medley become the basic building blocks of its formal design.

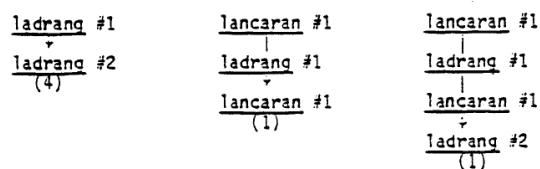

Figure 38. Non Talu-Related Sequences.

THE FORMAL PROCESS

The process by which a gamelan piece is realized is a complex interaction between a number of musical elements—some more-or-less fixed, others variable (Figure 39). The fixed elements of a piece discussed here include its structure, its balungan, and its formal design. Together, these do not themselves constitute a piece—which can only be brought into existence when it is realized in performance—but they do summarize the basic structural, melodic, and procedural information musicians must know in order to successfully realize a piece.

So much of what gives a performance of a piece its overall formal shape and interest is determined by choices the performers make in the actual moment of performance, where they breathe life into the rigid representation of a piece's fixed elements. They choose how many times to repeat a structural-melodic unit in a particular irama and with a particular treatment before transitioning to either repetitions of the same structural-melodic unit in another irama and treatment or to a different repeatable and expandable (in terms of irama) structural-melodic unit of the piece.

The musicians decide whether the flow of the performance will be continuous or disrupted, and what, if any, contrasting musical material they will insert into the performance of the piece. A remarkable characteristic of the Javanese gamelan tradition is that the way its performance practice has evolved makes it possible for any piece to retain its identity even as it is given new form each time it is performed by a group of competent musicians. ▀

[Note: A pdf of the complete original manuscript, including all Transcriptions and Appendices, is online and will be found in either "current issue" or in "back issues" at <http://www.gamelan.org/balungan>.—Ed.]

Endnotes

1. A few parts of the original manuscript, including its preface and appendices, are not included here but can be found in the pdf of the complete original work online.

2. The pitch frequencies (expressed in vibrations-per-second) and interval sizes (expressed in cents) for thirty-nine pelog gamelan and forty-six slendro gamelan are given in Kunst (1973:572-575).

3. The pelog instruments have an open octave. The slendro saron and slenthem, depending on where a gamelan was made, will have either a closed octave or a closed octave plus one pitch.

4. The idea of using circles to represent repeating cycles of colotomic punctuation in Javanese gamelan music comes from Hoffman (1975).

Bibliography

- Becker, Judith
1972 "Traditional Music in Modern Java." Ph.D. Dissertation, University of Michigan.
- Hoffman, Stanley Brian
1975 "Epistemology and Music in Java." M.A. Thesis, University of Michigan.
- Hood, Mantle
1971 *The Ethnomusicologist*. New York: McGraw-Hill.
_____, and Hardja Susilo.
1967 *Music of the Venerable Dark Cloud*. Los Angeles: Institute of Ethnomusicology, UCLA.
- Horne, Elinor Clark
1974 *Javanese-English Dictionary*. New Haven: Yale University Press.
- Kawindrasutikna; Sumanggakarsa, S.; and Sabirun
1974 *Gending-gending Beksan*. 2 vols. Yogyakarta: Konservatori Tari Indonesia.
- Kodiron
1973 *Serat Tuntunan*. Surakarta: T.S. "Pelajar."
- Kunst, Jaap
1973 *Music in Java*. 2 vols. 3rd ed. (E.L. Heins, ed.) The Hague: Martinus Nijhoff.
- Legowo, Budi
1973 *Karawitan Praktis*. 3 vols. Surakarta: Widya Duta.
- Martopangrawit, R.L.
1972 *Pengetahuan Karawitan*. Surakarta: Dewan Kesenian, Akademi Seni Karawitan Indonesia.
- Probohardjono, R. Ng. S.
1963 *Gending Djawi*. 2 vols. Surakarta: Sadu-Budi, .
1964 *Gending-gending: Ingkang Kangge Nabuhi Wayang Purwa*. Yogyakarta: Puspa Rahayu.
- Sindoesawarno, Ki
1963 *Ilmu Karawitan, Vol. 1*. Surakarta: Akademi Seni Karawitan Indonesia.
- Siswanta, M.
1971 *Teori dan Praktik Karawitan*. Yogyakarta: Konservatori Tari Indonesia.
1972 *Teori Karawitan*. Yogyakarta: Konservatori Tari Indonesia.
- Susilo, Hardja
1967 "Drumming in the Context of Javanese Gamelan." M.A. Thesis, Institute of Ethnomusicology, UCLA.
- Sutton, R. Anderson.
1975 "The Javanese Gamelan and its Music." M.A. Thesis, University of Hawaii. [Manuscript is online in the AGI Library at <http://www.gamelan.org>]
- Tenzer, Michael, ed.
2006 *Analytical Studies in World Music*. Oxford: Oxford University Press.

Discography

SOURCES

Key

RRIS	RRI Surakarta
RRİY	RRI Yogyakarta
ACD	Lokananta cassette
BRD	Lokananta LP
a-h	wayang recording series

Cassettes

Klenengan Gobjob. RRIS. ACD001
Klenengan Gobjob. RRIS. ACD002
Pangkur Djenggleng. RRIY. ACD003
Gending Soran. RRIS. ACD010
Gatutkatya Gandrung. RRIS. ACD011.
Sambul Gending. RRIS. ACD012.
Titipati. RRIS. ACD014.
Kinanti Djura Demung. RRIS. ACD015.
Gatutkaca Sungging. ACD022(a-h).
Uyon-Uyon Gobyog. RRIY. ACD024.
Condong Raos. Nartosabdho. ACD025.
Logondang. RRIS. ACD033.
Randanunut. RRIS. ACD034.
Pangkur. RRIS. ACD039.
Kresna Kembang. Nartosabdho. ACD051(a-h).
Jangkung Kuning. RRIS. ACD057.
Rujak Sentul. RRIS. ACD058.
Larawudho. RRIS. ACD070.
Rondhon. RRIS. ACD071.
Pancatnyana. RRIS ACD07

LPs

Gending Djawa (II). RRIS BRD002
Gending Djawa (III). RRIS BRD003
Gending Djawa (IV). RRIS BRD004
Gending Djawa (VII). RRIS BRD007
Gending Djawa (IX). RRIS BRD009
Gending Djawa (X). RRIS BRD010
Javanese Court Gamelan. Paku Alaman. Nonesuc H72044
Javanese Court Gamelan, Vol II. Mangkunegaran. Nonesuch
H72074
Gamelan Music from Centra Java. Surakarta. Philips 631 209PL

Field Recordings

Field tape, recorded by Roger Vetter in Yogyakarta at the
Paku Alaman on August 12, 1973.

PERFORMERS

RRI Yogyakarta. *Gamelan Kesenian Djawa Studio Yogyakarta*.
The radio station gamelan musicians in
Yogyakarta.
RRI Surakarta. *Gamelan Karawitan Studio Radio Republik
Indonesia*. The radio station gamelan musicians in
Surakarta.
Paku Alaman. The gamelan musicians from the Paku
Alaman palace in Yogyakarta.
Mangkunegaran. The gamelan musicians from the
Mangkunegaran palace in Surakarta.
[Kraton] Surakarta. The gamelan musicians from the main
palace in Surakarta.
Nartosabdho. A famous dhalang and musician with his own
gamelan group: *Condong Raos*.
Anom Soeroto. A dhalang with his own gamelan group:
Paguyuban Raras Irama.

SCORE

5 (*lima*)

by Aris Daryono

5 (lima) is a composition for 5 musicians playing Javanese rebab, gender barung (slendro and pelog), gambang, kempul, gongs, and computer. It was written between April 2004 and January 2006.

This is an interactive, semi-improvisatory composition with computer. The improvisation is similar to the traditional Javanese *pathetan*, in which the destination notes (*seleh*) guide the overall melodic line and flow of the performance. The computer connects players by recording them and feeding the sounds back as processed sound files. The computer is placed at the center of the stage, while each of the other instruments occupy a corner of the performance space. This piece reflects the Javanese philosophy "*sedulur papat, lima pancar*" (four brothers and ourselves as the center). This philosophy expresses the belief that we belong to a virtual family of five: ourself, surrounded by four spiritual brothers living in the north, south, east and west who always guide and protect us. Reflecting this, there should be a strong bond felt between the five musicians, in which there is always interaction, give and take, as well as individuality.

Instrumentation

Javanese gamelan

- two rebab, tuned to slendro 6/2, and pelog 5/1
- gambang pelog *bem* [1 2 3 5 6]
- gender barung slendro
- gender barung pelog *bem*
- gender barung pelog *barang* [7 2 3 5 6]
- kempul: slendro: 5, 1; pelog 5, 1, 7
- gong suwukan: slendro 2; pelog 1, 2
- gong ageng

Computer, running Max/MSP or similar software

Notation key for pelog, slendro, and gongs.

Pelog

Slendro

Gongs

Duration: 8 minutes or more.

Gamelan

Pitch 6 should be tumbuk (the same) in slendro and pelog. Pitch 5 slendro should be the same as 4 pelog.

Unless indicated otherwise, use the Javanese technique of damping each key after striking the next one.

In section I, the rebab and gambang will improvise in pelog nem. For both instruments, it is preferable to use traditional motifs or related variations.

The rebab is tuned to slendro 2 and 6 and, in Section IV, pelog 1 and 5. While there may be enough time to retune the rebab, it is easier to use two instruments, one in each tuning.

Gambang notation in section IV is intended only as a guide; the player may add or refine the notes according to his/her experience in playing traditional Javanese music.

Gender players are free to add or embellish the notes in section IV according to their experience in playing traditional Javanese gamelan music.

Abbreviations for gamelan

HM: hard mallet

SM: soft mallet

Computer

The computer should run Max/MSP music software, or any other compatible software that plays sound files and can process the sounds from a live performance.

Sub-patches

1. sp1: reverb, distortion, and pitch modulation.
2. sp2: record and play
3. sp3: reverb, delay, distortion, and pitch modulation.
4. sp4: play the sound files

Output

gt1: contains 4 speakers (left-front, right-front, right-rear, and left-rear).

gt2: surround sound 5.1 with hand control. The square symbols in the graphic sound score refer to the movement of the hand control on the surround sound.

Abbreviations for computer:

gt: gate/output
hctrl: hand control
lrf: left-front and right-front speakers
lrr: left-rear and right-rear speakers
middle: middle position of the surround sound
pmod: pitch modulation
sf: sound file
sp: sub-patch
st: store, i.e. storing the setting of Max/MSP in the computer

Selected Compositions by Aris Daryono

Kunang-Kunang (1996–1997), string orchestra
Into the Darkness (1997–1998), mixed ensemble
... and I Sleep (2001), French horn and piano
Sebuah Buku Tentang Aku, Kamu dan Mereka (2001–2002), violin and piano
A Place to Believe (2002), string quartet
Song of the Lord (2002), tenor and piano
A Space (2001–2002), mixed ensemble
Journey (2002), electronics
Ilir-ilir (2002), electronics
Ono Maling (2002), Javanese gamelan in slendro
Waktu Tersisa (2003), violin, flute and Javanese gamelan
Siang Pantara Ratri (2003–2004), female vocal, violin, Javanese gender barung (pelog bem and barang), ciblon, wood block, triangle, kempul in pelog
Sidhem, Bremara Kasireb (2004–2005), Javanese gamelan and orchestra
5 (Lima) (2004–2006), rebab, gender barung (slendro and pelog), gambang pelog bem, kempul, gongs, computer
Beautiful Error (2006), Javanese gender barung and panerus (slendro and pelog) and computer
Aku Gelisah (2006), Javanese gamelan and orchestra
Let Me Have a Dream (2006–2007), Javanese gamelan
Aku Berjalan, dari Sudut ke Sudut, di antara Sisi-Sisi (2006–2008), Javanese gender barung and gender panerus (slendro and pelog) and string quartet
Wus Kawiwit (2007–2008), male vocal, five or more snare drums
Padhang Bulan (2008), full Javanese gamelan
String Quartet No. 2 (2009)
Simple Mind (2010), Javanese saron (slendro and pelog, tumbuk 6)
Untitled (2010), gender barung and panerus slendro and pelog
Little Piece for Clarinet (2010), clarinet and piano
Layang-Layang (2010), gender barung and panerus slendro and pelog
Convenience Guild (2011), flute and Javanese gender barung and gender panerus (slendro and pelog)
Phaedra Suite (2012), male vocal, Javanese gender barung and panerus (slendro and pelog), gongs, kempul, and cello. i. Malam-Malam, ii. Woman I saw Cry, iii. Play Me A Tune

Gendhing Dolanan (2013), Javanese gender barung and panerus (slendro and pelog) and string quartet
Rasa (2013), two players on Javanese gender barung and panerus (slendro and pelog), flute, clarinet, oboe, cello
Sang Empu (2016), cello and ciblon
Suatu Saat (suite) (2016), violin and Javanese gender barung and panerus (slendro and pelog) i. Bisikan, ii. Kongkalikong, iii. Main Gila, iv. Daun Muda
Crowd (2017), Javanese gender barung and panerus (slendro and pelog), two diatonic instruments and audience
Distanced (2017), Javanese gender barung (slendro and pelog), two diatonic instruments and computer
“Quartet” (2017), any instruments (graphic score)
Papat (2018), Javanese gender barung and panerus (slendro and pelog) and two diatonic instruments (high and low registers)
..... (2018), solo piano

Some of these scores are available online at www.gamelan.org/composers/daryono

Aris Daryono is an Indonesian-born composer, Javanese gamelan musician, and teacher living in London. He studied classical guitar, composition and gamelan in Central Java, Indonesia. He received his Master's degree in composition at the Guildhall School of Music and Drama in London, and his Ph.D. in composition at the University of York.

His compositions reflect his background as a Javanese gamelan musician as well as his knowledge of western classical music. He has developed his unique musical language by blending the elements of gamelan music and western music to express his musical identity. In using European instruments, gamelan, and computer for this piece, Daryono explores and experiments with the sonority of the instruments. His music exploits microtones, the pulsing ombak [wave] effect in gamelan, and the sonic spectrum of the instruments by combining slendro, pelog, and diatonic tuning systems. He frequently collaborates with computer programmers, visual artists, contemporary dancers, shadow puppeteers, and folk musicians.

Daryono is the founder and director of the Gamelan Composers' Forum, an organization that has hosted, since 2013, the annual international event “Concert and Discussion of New Music for Gamelan,” held at the School of Oriental and African Studies (SOAS) in London.

Gamelan Tumbuk 6

The gamelan instruments should have the same pitch on note 6.

5

Rubato

Rebab
Gambang
Gender (Slendro+Pelog)
Max/MSP
Gong

Pelag Bem only

st 1

00:37 1 Play sfnoise1 (bead), sp1, gtl-circle slowly
7" p

00:30 2 Play sfnoise2 (string), sp3, gt2-middle
9" 5" 10" 1.v. 3" 9" 1.v. 1.v. free tempo
mf p

00:22 3 Play sfnoise3 (offstage), sp4, gtl-circle quickly
4" 4" 4" mf

01:47 4 Play sfnoise4 (loud), sp3, gt1-circle quickly
2" mp (sempre)

Aris Daryono



M/M
Gong

st 2

CP 2

00:38 1 Play sfnoise5 (wood), sp1, pmod, gtl-circle slowly
p 9" 15"

2 Play sfnoise2 (string), sp4, gtl-front
mp

middle (full speaker)
gate 1.
gate 2 in circle
middle (full speaker)
1.v. 3

J = 60
1p
is 7 is 7 is 7 ip

© 2006 Aris Daryono

2

(enter the stage)

Reb

M/M

Gong

1p

mp

sfz

1 | Tune the Rebab(s)

2 | Pick up the Rebab sound and use sp1, sp2

3 | Play sfz noise (scratch), sp3, p.midi, gt.1, Heiligkreis distortion

4 | rubato (similar)

5 | slendro

6 | I. v.

70

5p

5s

6

2p

*) | Scratching the edge of the gong at the back with a wooden mallet whilst the other hand plays the gong note at the front.



1

80

Gdr (SI) (+PL)

M/M

Gong

1p

mp

sfz

1 | hard mallets, div. pelog bem

2 | slendro

3 | I. v.

4 | RECORD &

5 | Playback, sp2, gt.1

6 | Playback, sp1, gt2, hctrl

7 | mp

8 | I. v.

9 | 5

10 | 5

11 | 5

♩ = 70

Improvisation based on the sound of the computer (noise7-chord) in Pelog Pathet 6 in gambang style.

hard mallets, div. *mp*

pelog beat

slendro *mf*

(suggested pattern 1)

(suggested pattern 2)

Gamb

Gdr (SI) (+PL)

M/M

Gong

mp (sempre)

free tempo

Gender (slendro) *mf* HM

Gender (pelog) *mf* HM

3 RECORD & PLAYBACK, sp3, gg2-middle



Improvisation based on the sound of the computer (noise7-chord) in Pelog Pathet 6, legato.

mf

3

Reb

Gamb

M/M

Gong

[Slendro] Wait a few moments after the gendfers have played their motifs, then start the solo. solo, free tempo (ca. 25 secs).

Repeat the motifs in the box and apply these dynamics, as seen as the solo rebab is heard.

Reb
Gamb
Gdr (SI)
Gdr (PL B/7)

Pick one of these motifs randomly and repeat it until the next bar.

Record and playback, sp3, gt l-rrear

Gamb
Gdr (SI)
Gdr (PL B/7)
M/M
Gong

6

Play these two motifs continuously in either stendro or pelog by following the most prominent tuning on the genders.

mf (sempre)

(^)

Pick one motif below, repeat it several times, then choose another one and repeat it. Vary them by using different octaves and different mallets (either hard or soft mallets).

mf

Reb
Gdr (Si)
Gdr (PL B/7)
Gong

Play this bar whenever you hear interlocking patterns played by genders.

Record and playback, sp2, gt1, lrrlear

Record and playback, sp3, gt2, circle quickly.

p

mf

p (*sempre*)

st 5

5p, 1p, 5p, 1p, 5p, 1p

5s, 5s, 5s, 5s, 5s, 5s

Reb
Gamb
Gdr (Si)
Gdr (PL B/7)
M/M
Gong

III $\text{♩} = 135$ Change/tune to pelog 5

Rebab

Gambus

Gendang (SI)

Gendang (PL B/7)

M/M

Gong

Use hard mallets only...
one mallet for each player.

ff (as possible)

mf

f

5p)

1s 5s

1s 5s

p

IV Rubato, free tempo, for 02'50" - 03'30"

Rebab

Gambus

Gendang (SI)

M/M

mp

mp

mp

pp

03'20
[Play sfnoise8(gong), sp4, g2, middle]

*) repeat the motif in the box as many times as required in order to follow the rebab.

Rebab
Gambus
Gendang (SI)
M/M



Rebab
Gambus
Gendang (SI)
M/M

The musical score is arranged in five staves, labeled from top to bottom as follows:

- Reb**: Treble clef, starting with a whole note chord.
- Gamb**: Treble clef, featuring a melodic line with slurs and accents.
- Gdr (Sl)**: Treble clef, playing a rhythmic accompaniment with eighth notes.
- M/M**: Treble clef, playing a rhythmic accompaniment with eighth notes.
- Gong**: Bass clef, playing a sustained low note with a dynamic marking of *mp*.

Key features of the score include:

- Vertical dashed lines indicating synchronization between the instruments.
- Dynamic markings: *mp* (mezzo-piano) in the Gong part.
- Performance instructions: *l.v.* (lento) markings above the Gamb and Gdr (Sl) staves.
- A wavy line across the bottom of the M/M and Gong staves, likely indicating a tremolo or sustained effect.

total duration: 08'00 or more.

POEM

Pamor [As One]

by Peni Candra Rini

JAVANESE

“Pamor”

Ayang-ayang ira lan ndika,
Nir winates werna lan mangsa
Amung pethak cemeng lan anteng
Among pamor sih
Agem tajem sidhem
Tresna nir swara
Jagad Anuraga.

ENGLISH

“As One”

Her shadow and yours,
Without bounds of colour or time,
Just white, black and calm,
Cherishing the bonds of love,
Holding tight, firm and soundless
A love that needs no voice,
A wide world of deep Affection.

INDONESIAN

Bayangan ku dan kamu.
Tanpa batas warna dan musim.
Hanya putih, hitam dan keteguhan.
Menjaga cahaya kasih,
Sangat menghormatimu setajam sunyi.
Cinta tak terucap.
Dalam semesta Kasih.



Peni Candra Rini is a singer and composer on the faculty of ISI Surakarta. She wrote this Javanese poem to perform as a song. Peni explains that it was inspired by the feeling she had when looking at this photograph of the combined shadows of herself and her young son. The English and Indonesian translations are not sung, but used to explain the meaning of the poem.

Pamor refers to the pattern or design on the blade of a *kris*, a Javanese ceremonial dagger.

Photo, Javanese, and Indonesian by Peni Candra Rini.
English translation by Stuart Robson.

You are invited
on the Winter Solstice, 21 December 2019
(and every Winter Solstice thereafter)
to hold a screening of



the interreligious music video
MANDALA SALAM

followed by sharing art and discussion

on youtube at <https://is.gd/mandalasalam>

This video presents works by Indonesian Christian, Hindu, Muslim, and Buddhist composers Dedek Wahyudi, I Wayan Sadra, Waridi Harjakusuma, Waluyo Sastro Sukarno, and R.L. Martopangrawit, with Slamet Gundono, mantra by Pujo Darmosurjo, and 53 musicians, recorded at Institut Seni Indonesia Surakarta

an offering for

"Infinite Humanity: World Religions & Art for Peace and Respect of Life"
a gathering in prayer event that opened in the United Nations Meditation Room at 12 noon on the 21 December Solstice 2001 followed by three days of art and prayer by over 150 artists and religious leaders from 11 nations circulating "Ground Zero" and at the Williamsburg Art & Historical (WAH) Center in Brooklyn, New York, and parallel events worldwide in 35 villages and cities in 15 nations

inspired by

the 1986 World Day of Prayer for Peace at Assisi, the ideas of St. Francis, the Spanish Sufi Ibn al-'Arab, Hindu leader Mahatma Gandhi and others, the eleventh century Balinese Samuan Tiga temple approach of unity in diversity, and as a response to the loss of lives of people from 70 nations in New York City on 11 September 2001 and in places of strife in the world

Mandala Salam premiered on 22 December 2001 at the WAH Center in Brooklyn as part of an art exhibition and evening of performances including Topeng Sidhakarja masked-dance by I Nyoman Catra, a film by Phill Niblock, new compositions by Sumarsam and Harjito with Gamelan Dharma Swara, Sabbath Bride by Jody Diamond played by Gamelan Son of Lion with dance by Deena Burton, wayang by Marc Hoffman, prayer by Ida Pedanda Arimbawa, and Anicca movement ritual by Suprpto Suryodarmo, Diane Butler, and Yin Mei.

with peace

video co-producers: Studio Sembilanbelas of STSI, Padepokan Lemah Putih,
ISI Surakarta, International Foundation for Dharma Nature Time,
American Gamelan Institute, 1stPictures Indonesia

The fonts on this page are Lou Titling and Pluma, designed by Lou Harrison and realized by Carter Scholz.

